

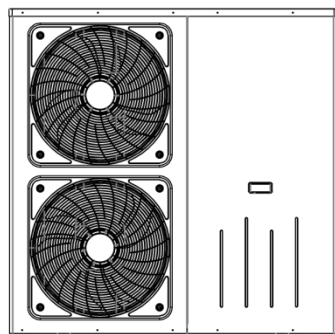

Inverter Heating&Cooling Heat Pump

Installation & Instruction Manual

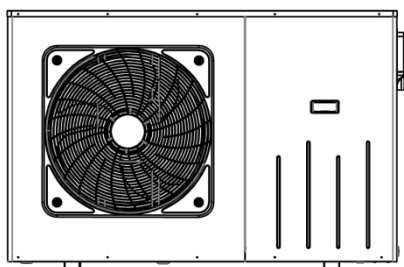

IMPORTANT NOTE:

Thank you very much for purchasing our product. Before using your unit, please read this manual carefully and keep it for future reference.

CONTENT

1. FOREWORD.....	1
1.1. Read the Manual Before Operation.....	1
1.2. The Symbol Description of the Device.....	6
1.3. Statement.....	6
1.4. Safety Factors.....	6
2. OVER VIEW OF THE UNIT.....	9
2.1. Dimensions of the Unit.....	9
2.2. Main Parts of the Unit.....	10
2.3. Parameter of the Unit.....	12
3. INSTALLATION AND CONNECTION.....	13
3.1. Transportation.....	13
3.2. Installation Instruction.....	13
3.2.1. Pre-requirements.....	13
3.2.2. Location and Space.....	13
3.2.3. Installation Layout.....	15
3.2.4. Electrical Installation.....	15
3.2.5. Electrical Connection.....	16
3.3. Trial After Installation.....	17
3.3.1. Inspection Before Trial Running.....	17
3.3.2. Trial Running.....	17
4. REMOTE CONTROLLER OPERATION GUIDANCE.....	17
4.1. Main Interface.....	17
4.2. Key Operating Instruction.....	18
4.2.1. ON/OFF Function.....	18
4.2.2. Mode Selection Function.....	18
4.2.3. Current Mode Target Temp. Setting.....	19
4.2.4. Check Parameter Status.....	19
4.2.5. Lock/Unlock Function.....	20

4.2.6. Setting Interface.....	20
4.2.7. System Parameter Interface.....	20
4.2.8. Mute and Timer Mute Setting Function.....	27
4.2.9. Time Setting Function.....	28
4.2.10. Electric Heating Function.....	29
4.2.11. Timer Setting Function.....	29
4.2.12. Curve.....	30
4.3. User Parameter.....	31
4.4. Trouble Shooting.....	32
5. Wi-Fi FUNCTION.....	34
5.1. Software Installation.....	34
5.2. Software Startup.....	34
5.3. Software Registration and Configuration.....	35
5.4. WI-FI Connection.....	38
5.5. Software Function Operation.....	42
5.6. Device Removal.....	49
6. MAINTENANCE AND WINTERZING.....	50
6.1. Maintenance.....	50
6.2. Winterizing.....	50

1. FOREWORD

1.1. Read the Manual Before Operation

WARNING

Do not use means to accelerate the defrosting process or to clean, other than those recommended by the manufacturer. The appliance shall be stored in a room without continuously operating ignition sources (for example: open flames, an operating gas appliance or an operating electric heater).

Do not pierce or burn.

Be aware that refrigerants may not contain an odour.

Initial safety checks shall include:

- ① That capacitors are discharged: this shall be done in a safe manner to avoid possibility of sparking;
- ② That no live electrical components and wiring are exposed while charging, recovering or purging the system;
- ③ That there is continuity of earth bonding.

Checks to the area

Prior to beginning work on systems containing flammable refrigerants, safety checks are necessary to ensure that the risk of ignition is minimized. For repair to the refrigerating system, the following precautions shall be completed prior to conducting work on the system.

Work procedure

Work shall be undertaken under a controlled procedure so as to minimize the risk of a flammable gas or vapour being present while the work is being performed.

General work area

All maintenance staff and others working in the local area shall be instructed on the nature of work being carried out. Work in confined spaces shall be avoided.

Checking for presence of refrigerant

The area shall be checked with an appropriate refrigerant detector prior to and during work, to ensure the technician is aware of potentially flammable atmospheres. Ensure that the leak detection equipment being used is suitable for use with flammable refrigerants, i.e. non-sparking, adequately sealed or intrinsically safe.

Presence of fire extinguisher

If any hot work is to be conducted on the refrigerating equipment or any associated parts, appropriate fire extinguishing equipment shall be available to hand. Have a dry powder or CO₂ fire extinguisher adjacent to the charging area.

No ignition sources

No person carrying out work in relation to a refrigeration system which involves exposing any pipe work that contains or has contained flammable refrigerant shall use any sources of ignition in such a manner that it may lead to the risk of fire or explosion. All possible ignition sources, including cigarette smoking, should be kept sufficiently far away from the site of installation, repairing, removing and disposal, during which flammable refrigerant can possibly be released to the surrounding space. Prior to work taking place, the area around the equipment is to be surveyed to make sure that there are no flammable hazards or ignition risks. "No Smoking" signs shall be displayed.

Ventilated area

Ensure that the area is in the open or that it is adequately ventilated before breaking into the system or conducting any hot work. A degree of ventilation shall continue during the period that the work is carried out. The ventilation should safely disperse any released refrigerant and preferably expel it externally into the atmosphere.

Checks to the refrigeration equipment

Where electrical components are being changed, they shall be fit for the purpose and to the correct specification. At all times the manufacturer's maintenance and service guidelines shall be followed. If in doubt consult the manufacturer's technical department for assistance.

The following checks shall be applied to installations using flammable refrigerants:

- ① The charge size is in accordance with the room size within which the refrigerant containing parts are installed;
- ② The ventilation machinery and outlets are operating adequately and are not obstructed;
- ③ If an indirect refrigerating circuit is being used, the secondary circuit shall be checked for the presence of refrigerant;
- ④ Marking to the equipment continues to be visible and legible. Markings and signs that are illegible shall be corrected;
- ⑤ Refrigeration pipe or components are installed in a position where they are unlikely to be exposed to any substance which may corrode refrigerant containing components, unless the components are constructed of materials which are inherently resistant to being corroded or are suitably protected against being so corroded.

Repairs to sealed components

DD.5.1 During repairs to sealed components, all electrical supplies shall be disconnected from the equipment being worked upon prior to any removal of sealed covers, etc. If it is absolutely necessary to have an electrical supply to equipment during servicing, then a permanently operating form of leak detection shall be located at the most critical point to warn of a potentially hazardous situation.

DD.5.2 Particular attention shall be paid to the following to ensure that by working on electrical components, the casing is not altered in such a way that the level of protection is affected. This shall include damage to cables, excessive number of connections, terminals not made to original specification, damage to seals, incorrect fitting of glands, etc.

Ensure that the apparatus is mounted securely.

Ensure that seals or sealing materials have not degraded to the point that they no longer serve the purpose of preventing the ingress of flammable atmospheres. Replacement parts shall be in accordance with the manufacturer's specifications.

Repair to intrinsically safe components

Do not apply any permanent inductive or capacitance loads to the circuit without ensuring that this will not exceed the permissible voltage and current permitted for the equipment in use. Intrinsically safe components are the only types that can be worked on while live in the presence of a flammable atmosphere. The test apparatus shall be at the correct rating.

Replace components only with parts specified by the manufacturer. Other parts may result in the ignition of refrigerant in the atmosphere from a leak.

NOTE The use of silicon sealant can inhibit the effectiveness of some types of leak detection equipment.

Intrinsically safe components do not have to be isolated prior to working on them.

Cabling

Check that cabling will not be subject to wear, corrosion, excessive pressure, vibration, sharp edges or any other adverse environmental effects. The check shall also take into account the effects of aging or continual vibration from sources such as compressors or fans.

Detection of flammable refrigerants

Under no circumstances shall potential sources of ignition be used in the searching for or detection of refrigerant leaks. A halide torch (or any other detector using a naked flame) shall not be used.

Leak detection methods

The following leak detection methods are deemed acceptable for systems containing flammable refrigerants.

Electronic leak detectors shall be used to detect flammable refrigerants, but the sensitivity may not be adequate, or may need re-calibration. (Detection equipment shall be calibrated in a refrigerant-free area.) Ensure that the detector is not a potential source of ignition and is suitable for the refrigerant used. Leak detection equipment shall be set at a percentage of the LFL of the refrigerant and shall be calibrated to the refrigerant employed and the appropriate percentage of gas (25 % maximum) is confirmed.

Leak detection fluids are suitable for use with most refrigerants but the use of detergents containing chlorine shall be avoided as the chlorine may react with the refrigerant and corrode the copper pipe-work.

If a leak is suspected, all naked flames shall be removed/extinguished.

If a leakage of refrigerant is found which requires brazing, all of the refrigerant shall be recovered from the system, or isolated (by means of shut off valves) in a part of the system remote from the leak. Oxygen free nitrogen (OFN) shall then be purged through the system both before and during the brazing process.

Removal and evacuation

When breaking into the refrigerant circuit to make repairs – or for any other purpose – conventional procedures shall be used. However, it is important that best practice is followed since flammability is a consideration. The following procedure shall be adhered to:

- ① Remove refrigerant;
- ② Purge the circuit with inert gas;
- ③ Evacuate;
- ④ Purge again with inert gas;
- ⑤ Open the circuit by cutting or brazing.

The refrigerant charge shall be recovered into the correct recovery cylinders. The system shall be “flushed” with OFN to render the unit safe. This process may need to be repeated several times. Compressed air or oxygen shall not be used for this task.

Flushing shall be achieved by breaking the vacuum in the system with OFN and continuing to fill until the working pressure is achieved, then venting to atmosphere, and finally pulling down to a vacuum. This process shall be repeated until no refrigerant is within the system. When the final OFN charge is used, the system shall be vented down to atmospheric pressure to enable work to take place. This operation is absolutely vital if brazing operations on the pipework are to take place.

Ensure that the outlet for the vacuum pump is not close to any ignition sources and there is ventilation available.

Charging procedures

In addition to conventional charging procedures, the following requirements shall be followed:

- ① Ensure that contamination of different refrigerants does not occur when using charging equipment. Hoses or lines shall be as short as possible to minimize the amount of refrigerant contained in them. Cylinders shall be kept upright.
- ② Ensure that the refrigeration system is earthed prior to charging the system with refrigerant.
- ③ Label the system when charging is complete (if not already).
- ④ Extreme care shall be taken not to overfill the refrigeration system. Prior to recharging the system it shall be pressure tested with OFN. The system shall be leak tested on completion of charging but prior to commissioning. A follow up leak test shall be carried out prior to leaving the site.

Decommissioning

Before carrying out this procedure, it is essential that the technician is completely familiar with the equipment and all its detail. It is recommended good practice that all refrigerants are recovered safely. Prior to the task being carried out, an oil and refrigerant sample shall be taken in case analysis is required prior to re-use of reclaimed refrigerant. It is essential that electrical power is available before the task is commenced.

- ① Become familiar with the equipment and its operation.
- ② Isolate system electrically.
- ③ Before attempting the procedure ensure that:
 - Mechanical handling equipment is available, if required, for handling refrigerant cylinders;
 - All personal protective equipment is available and being used correctly;

- The recovery process is supervised at all times by a competent person;
- Recovery equipment and cylinders conform to the appropriate standards.
- ④ Pump down refrigerant system, if possible.
- ⑤ If a vacuum is not possible, make a manifold so that refrigerant can be removed from various parts of the system.
- ⑥ Make sure that cylinder is situated on the scales before recovery takes place.
- ⑦ Start the recovery machine and operate in accordance with manufacturer's instructions.
- ⑧ Do not overfill cylinders. (No more than 80 % volume liquid charge).
- ⑨ Do not exceed the maximum working pressure of the cylinder, even temporarily.
- ⑩ When the cylinders have been filled correctly and the process completed, make sure that the cylinders and the equipment are removed from site promptly and all isolation valves on the equipment are closed off.
- ⑪ Recovered refrigerant shall not be charged into another refrigeration system unless it has been cleaned and checked.

Labeling

Equipment shall be labeled stating that it has been decommissioned and emptied of refrigerant. The label shall be dated and signed. Ensure that there are labels on the equipment stating the equipment contains flammable refrigerant.

Recovery

When removing refrigerant from a system, either for servicing or decommissioning, it is recommended good practice that all refrigerants are removed safely. When transferring refrigerant into cylinders, ensure that only appropriate refrigerant recovery cylinders are employed. Ensure that the correct number of cylinders for holding the total system charge are available. All cylinders to be used are designated for the recovered refrigerant and labeled for that refrigerant (i.e. special cylinders for the recovery of refrigerant). Cylinders shall be complete with pressure relief valve and associated shut-off valves in good working order. Empty recovery cylinders are evacuated and, if possible, cooled before recovery occurs.

The recovery equipment shall be in good working order with a set of instructions concerning the equipment that is at hand and shall be suitable for the recovery of flammable refrigerants.

In addition, a set of calibrated weighing scales shall be available and in good working order.





Hoses shall be complete with leak-free disconnect couplings and in good condition. Before using the recovery machine, check that it is in satisfactory working order, has been properly maintained and that any associated electrical components are sealed to prevent ignition in the event of a refrigerant release. Consult manufacturer if in doubt.

The recovered refrigerant shall be returned to the refrigerant supplier in the correct recovery cylinder, and the relevant Waste Transfer Note arranged. Do not mix refrigerants in recovery units and especially not in cylinders.

If compressors or compressor oils are to be removed, ensure that they have been evacuated to an acceptable level to make certain that flammable refrigerant does not remain within the lubricant. The evacuation process shall be carried out prior to returning the compressor to the suppliers. Only electric heating to the compressor body shall be employed to accelerate this process. When oil is drained from a system, it shall be carried out safely.

1.2. The Symbol Description of the Device

The precautions listed here are divided into the following types. They are quite important, so be sure to follow them carefully. Meanings of DANGER, WARNING, CAUTION and NOTE symbols.

Symbols	Meaning	Description
	WARNING	The symbol shows that this appliance uses a flammable refrigerant. If the refrigerant is leaked and exposed to an external ignition source, there is a risk of fire.
	WARNING	The symbol shows that this appliance uses a low burning velocity material. Please keep away from fire source.
	CAUTION	This symbol shows that the operation manual should be read carefully.
	CAUTION	This symbol shows that a service personnel should be handling this equipment with reference to the installation manual.
	CAUTION	This symbol shows that information is available such as the operating manual or installation manual.

1.3. Statement

To keep users under safe working condition and property safety, please follow the instructions below:

- ① Wrong operation may result in injury or damage;
- ② Please install the unit in compliance with local laws, regulations and standards;
- ③ Confirm power voltage and frequency;
- ④ The unit is only used with grounding sockets;
- ⑤ Independent switch must be offered with the unit.

1.4. Safety Factors

The following safety factors need to be considered:

- ① Please read the following warnings before installation;
- ② Be sure to check the details that need attention, including safety factors;
- ③ After reading the installation instructions, be sure to save them for future reference.

Warning

Make sure that the unit is installed safely and reliably.

- If the unit is not secure or not installed, it may cause damage. The minimum support weight required for installation is 21g/mm²

- If the unit was installed in a closed area or limited space, please consider the size of room and ventilation to prevent suffocation caused by refrigerant leakage.

- ① Use a specific wire and fasten it to terminal block so that the connection will prevent pressure from being applied to parts.

- ② Wrong wiring will cause fire.

Please connect power wire accurately according to wiring diagram on the manual to avoid burnout of the unit or fire.

- ③ Be sure to use correct material during installing.

Wrong parts or wrong materials may result in fire, electric shock, or falling of the unit.

- ④ Install on the ground safely, please read installation instructions.

Improper installation may result in fire, electric shock, falling of the unit, or water leaking.

- ⑤ Use professional tools for doing electrical work.

If power supply capacity is insufficient or circuit is not completed, it may cause fire or electric shock.

- ⑥ The unit must have grounding device.

If power supply does not have grounding device, be sure not to connect the unit.

- ⑦ The unit should be only removed and repaired by professional technician.

Improper movement or maintenance of the unit may cause water leakage, electric shock, or fire.

Please find a professional technician to do.

- ⑧ Don't unplug or plug power during operation. It may cause fire or electric shock.

- ⑨ Don't touch or operate the unit when your hands are wet. It may cause fire or electric shock.

- ⑩ Don't place heaters or other electrical appliances near the power wire. It may cause fire or electric shock.

- ⑪ The water must not be poured directly from the unit. Do not let water to permeate into the electrical components.

 **Warning**

- ① Do not install the unit in a location where there may be flammable gas.

- ② If there is flammable gas around the unit, it will cause explosion.

According to the instruction to carry out drainage system and pipeline work. If drainage system or pipeline is defective, water leakage will occur. And it should be disposed immediately to prevent other household products from getting wet and damage.

- ③ Do not clean the unit while power is on. Turn off power before cleaning the unit. If not it may result in injury from a high-speed fan or electric shock.

- ④ Stop operating the unit once there is a problem or an fault code.

Please turn off power and stop running the unit. Otherwise it may cause electric shock or fire.

- ⑤ Be careful when the unit is not packed or not installed.

Pay attention to sharp edges and fins of heat exchanger.

- ⑥ After installation or repair, please confirm refrigerant is not leaking.

If refrigerant is not enough, the unit will not work properly.

- ⑦ The installation of external unit must be flat and firm.

Avoid abnormal vibration and noise.

- ⑧ Don't put your fingers into fan and evaporator.

High speed running fan will result in serious injury.

⑨ This device is not designed for people who is physically or mentally weak (including children) and who does not have experience and knowledge of heating and cooling system. Unless it is used under direction and supervision of professional technician, or has received training on the using of this unit. Children must use it under supervision of an adult to ensure that they use the unit safely. If power wire is damaged, it must be replaced by a professional technician to avoid danger.

2. OVER VIEW OF THE UNIT

2.1. Dimensions of the Unit

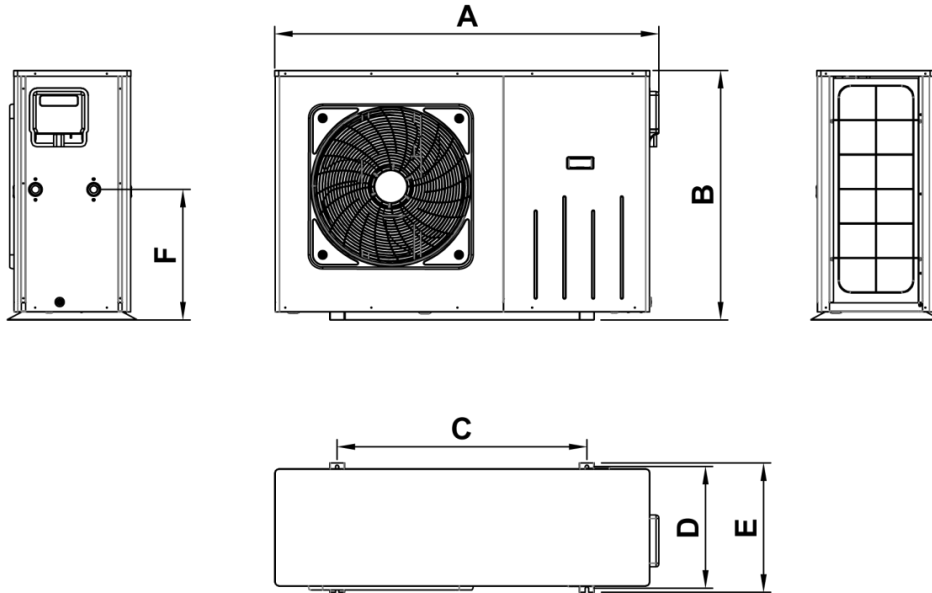

Dimension Unit: (mm)

Model	A	B	C	D	E	F
NE-F90HCR4INVM-A	1338	869	870	424	450	455
NE-F120HCR4INVM-A						

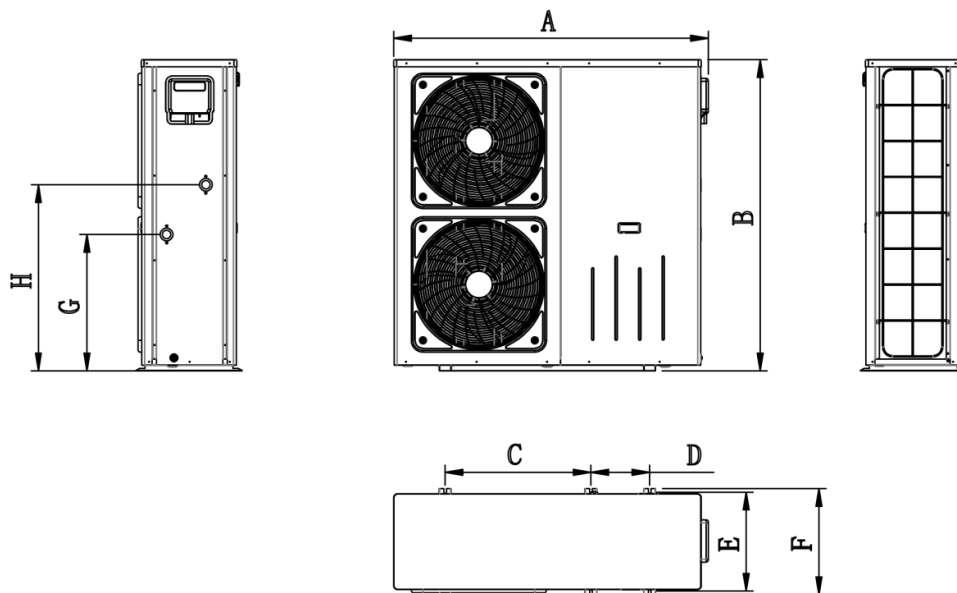

Dimension Unit: (mm)

Model	A	B	C	D	E	F	G	H
NE-F200HCR4TINVM-A	1338	1322	620	250	420	450	580	790

2.2. Main Parts of the Unit

NE-F90HCR4INVM-A

NE-F120HCR4INVM-A

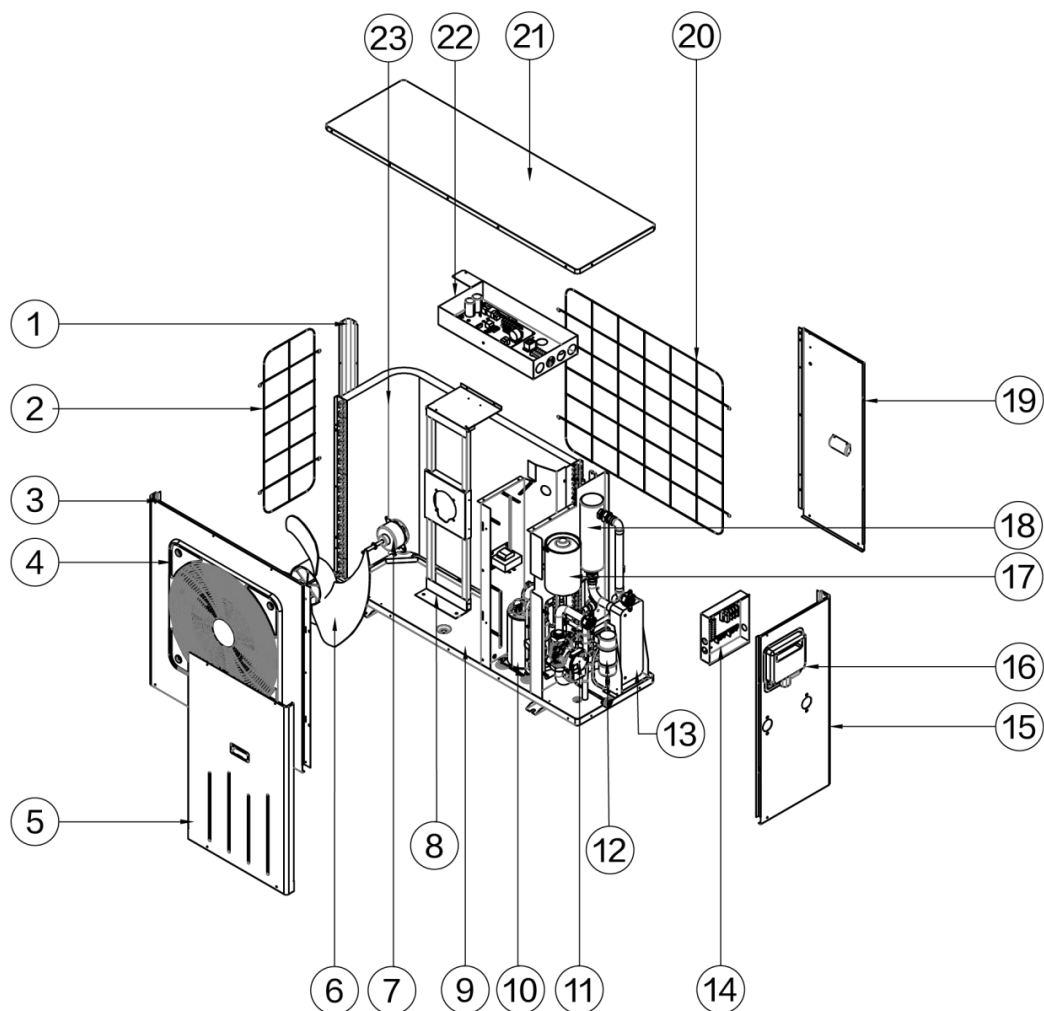

①	Column	⑨	Chassis	⑰	Expansion Tank
②	Left Net	⑩	Compressor	⑱	Electric Heating
③	Air Guide Plate	⑪	Water Pump	⑲	Back Service Plate
④	Mesh Cover	⑫	Liquid Reservoir	⑳	Back Net
⑤	Front Service Plate	⑬	Plate Heat Exchanger	㉑	Top Cover
⑥	Fan Blade	⑭	Junction Box	㉒	Electrical Box
⑦	Fan Motor	⑮	Right Plate	㉓	Evaporator
⑧	Motor Support	⑯	Handle		

NE-F200HCR4TINVM-A

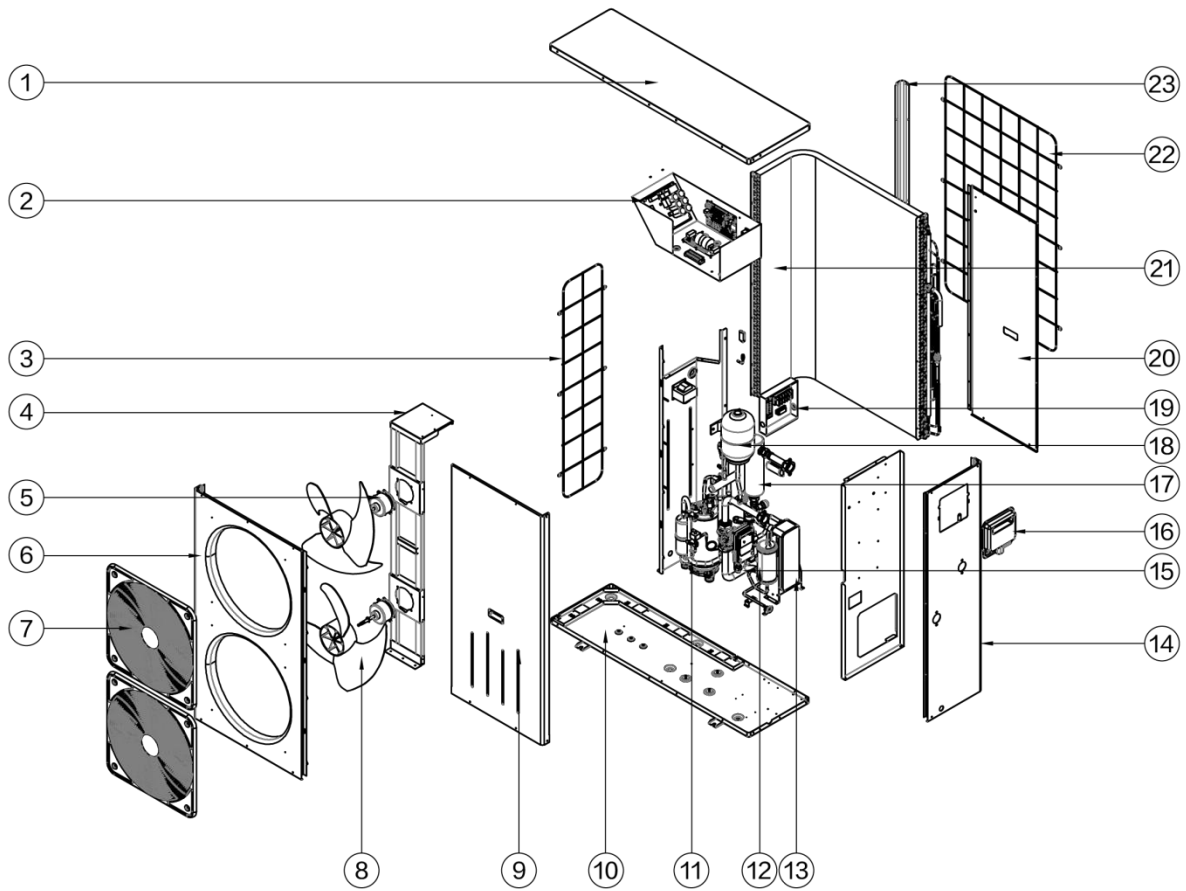

①	Top Cover	⑨	Front Service Plate	⑰	Electric Heating
②	Electrical Box	⑩	Chassis	⑱	Expansion Tank
③	Left Net	⑪	Compressor	⑲	Junction Box
④	Motor Support	⑫	Liquid Reservoir	⑳	Back Service Plate
⑤	Fan Motor	⑬	Plate Heat Exchanger	㉑	Evaporator
⑥	Fan Blade	⑭	Right Plate	㉒	Back Net
⑦	Mesh Cover	⑮	Water Pump	㉓	Column
⑧	Air Guide Plate	⑯	Handle		

2.3. Parameter of the Unit

Model:NE-F	90HCR4INVM-A	120HCR4INVM-A	200HCR4TINVM-A
Operation Range (°C)	-20~43°C		
Max. Outlet Water Temp. (°C)	55		
Power Supply	220-240V~/50Hz		380V-415V/3N ~/ 50Hz
[House Heating] Ambient Temperature: (DB/WB) 7°C/6°C; Water Inlet/Outlet Temperature: 30°C/35°C.			
Heating Capacity (kW)	8.75	11.7	18.9
Power Input(kW)	1.890	2.680	4.172
COP	4.64	4.37	4.53
[House Heating] Ambient Temperature: (DB/WB) 7°C/6°C; Water Inlet/Outlet Temperature: 50°C/55°C.			
Heating Capacity (kW)	7.83	9.95	16.82
Power Input(kW)	3.132	4.000	6.087
COP	2.5	2.49	2.7633
[Water Heater] Ambient Temperature: (DB/WB) 20°C/15°C; Water Temperature from 15°C to 55°C.			
Heating Capacity (kW)	10	12.5	20.2
Power Input(kW)	2.123	2.665	4.316
COP	4.71	4.69	4.68
Ambient Temperature: (DB/WB) 35°C / -; Water Inlet/Outlet Temperature: 12°C/7°C.			
Cooling Capacity (kW)	8.27	9.77	18.3
Power Input (kW)	3.620	3.620	6.421
EER	2.29	2.7	2.85
Max. Power Input (kW)	4	4.4	6.8
Max. Running Current (A)	18.1	20	12
Electric Heater Rated Input (kW)	3		
Compressor Brand	Mitsubishi		
Water Side Heat Exchanger	Brazen plate heat exchanger		
Air Side Heat Exchanger	High efficiency finned heat exchanger		
Wi-Fi Function	Yes		
Rated Water Flow (m³/h)	1.49	1.98	3.25
Water Pressure Drop (kPa)	20	22	28
Water Pipe Connection (inch)	1 1/4"		
Sound Pressure Level dB(A) 1m	58	59	64
Refrigerant Type	R32		
Water Proof Class	IPX4		
Electricity Shock Proof	I		
Net Weight (kg)	95	97	
Gross Weight (kg)	100	102	
Net Dimensions(L×W×H) (mm)	1338x450x870		1338x450x1320
Shipping Dimensions(L×W×H) (mm)	1415x470x1020		1415x470x1472

3. INSTALLATION AND CONNECTION

⚠ WARNING: The heat pump must be installed by a professional team. The users are not qualified to install by themselves, otherwise the heat pump might be damaged and risky for users' safety.

This section is provided for information purposes only and must be checked and adapted if necessary according to the actual installation conditions.

3.1. Transportation

1. When storing or moving the heat pump, the heat pump should be at the upright position.

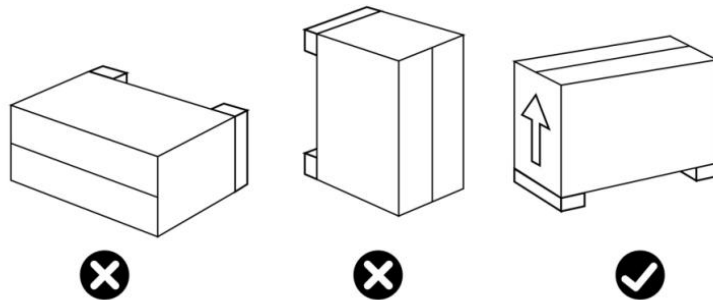

2. When moving the heat pump, do not lift the water union since the titanium heat exchanger inside the heat pump will be damaged.

3.2. Installation Instruction

3.2.1. Pre-requirements

Equipment necessary for the installation of your heat pump:

- ① Power supply cable suitable for the unit's power requirements.
- ② A By-Pass kit and an assembly of PVC tubing suitable for your installation as well as stripper, PVC adhesive and sandpaper.
- ③ A set of wall plugs and expansion screws suitable to attach the unit to your support.
- ④ We recommend that you connect the unit to your installation by means of flexible PVC pipes in order to reduce the transmission of vibrations.
- ⑤ Suitable fastening studs may be used to raise the unit.

3.2.2. Location and Space

Please comply with the following rules concerning the choice of heat pump location.

- ① The unit's future location must be easily accessible for convenient operation and maintenance.
- ② It must be installed on the ground, fixed ideally on a level concrete floor. Ensure that the floor is sufficiently stable and can support the weight of the unit.
- ③ A water drainage device must be provided close to the unit in order to protect the area where it is installed.

- ④ If necessary, the unit may be raised by using suitable mounting pads designed to support its weight.
- ⑤ Check that the unit is properly ventilated, that the air outlet is not facing the windows of neighbouring buildings and that the exhaust air cannot return. In addition, provide sufficient space around the unit for servicing and maintenance operations.
- ⑥ The unit must not be installed in an area exposed to oil, flammable gases, corrosive products, sulphur compounds or close to high frequency equipment.
- ⑦ To prevent mud splashes, do not install the unit near a road or track.
- ⑧ To avoid causing nuisance to neighbors, make sure the unit is installed so that it is positioned towards the area that is least sensitive to noise.
- ⑨ Keep the unit as much as possible out of the reach of children.
- ⑩ Installation space:

The unit shall be installed in a place with air circulation, no heat radiation or other heat sources, and the allowable minimum distance between the unit and the surrounding walls or other shelters is: the distance between the air inlet surface and the air inlet surface is more than 300 mm, the distance between every 2 units is more than 600 mm, as shown in the figure:

Unit: mm

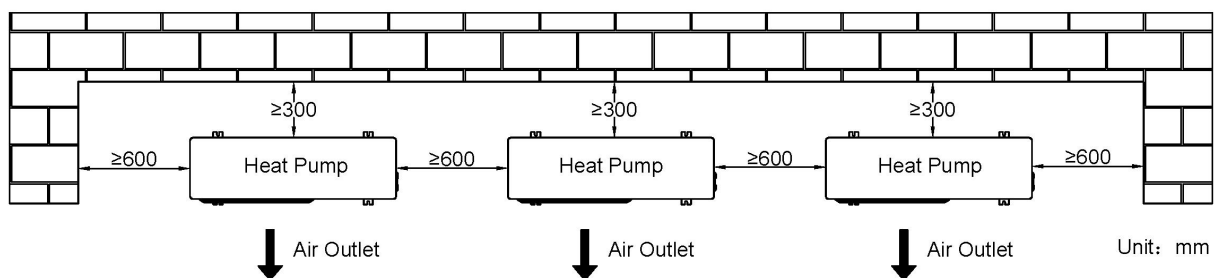

In snowy areas, anti-snow facilities shall be installed. In order not to be affected by snow, elevated platform is adopted, and anti-snow shed is installed at air inlet and air outlet.

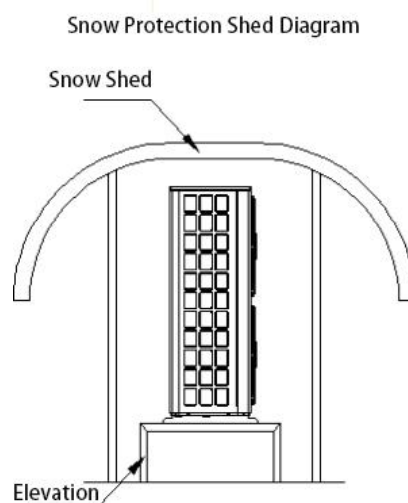

3.2.3. Installation Layout

Notice:

- ① Flexible connection between unit and circulating water pipe can prevent vibration from unit to water pipe.
- ② The gate valve must be installed at the inlet/outlet of the unit. When the pressure test is completed after the installation of the end of the water system, the gate valve shall be closed for pressure test.
- ③ Open after discharge.
- ④ "Y" filter (60 mesh) must be installed at the inlet pipe of the main engine to effectively prevent impurities from damaging the unit.
- ⑤ Clean water quality and usage regularly.
- ⑥ Installation of relief valve, bypass valve and other valve parts must be in the direction of the arrow of the valve body.
- ⑦ After installation, water injection is required to detect leakage, confirm no leakage, and clean the filter.

The installation diagram is shown in the following figure:

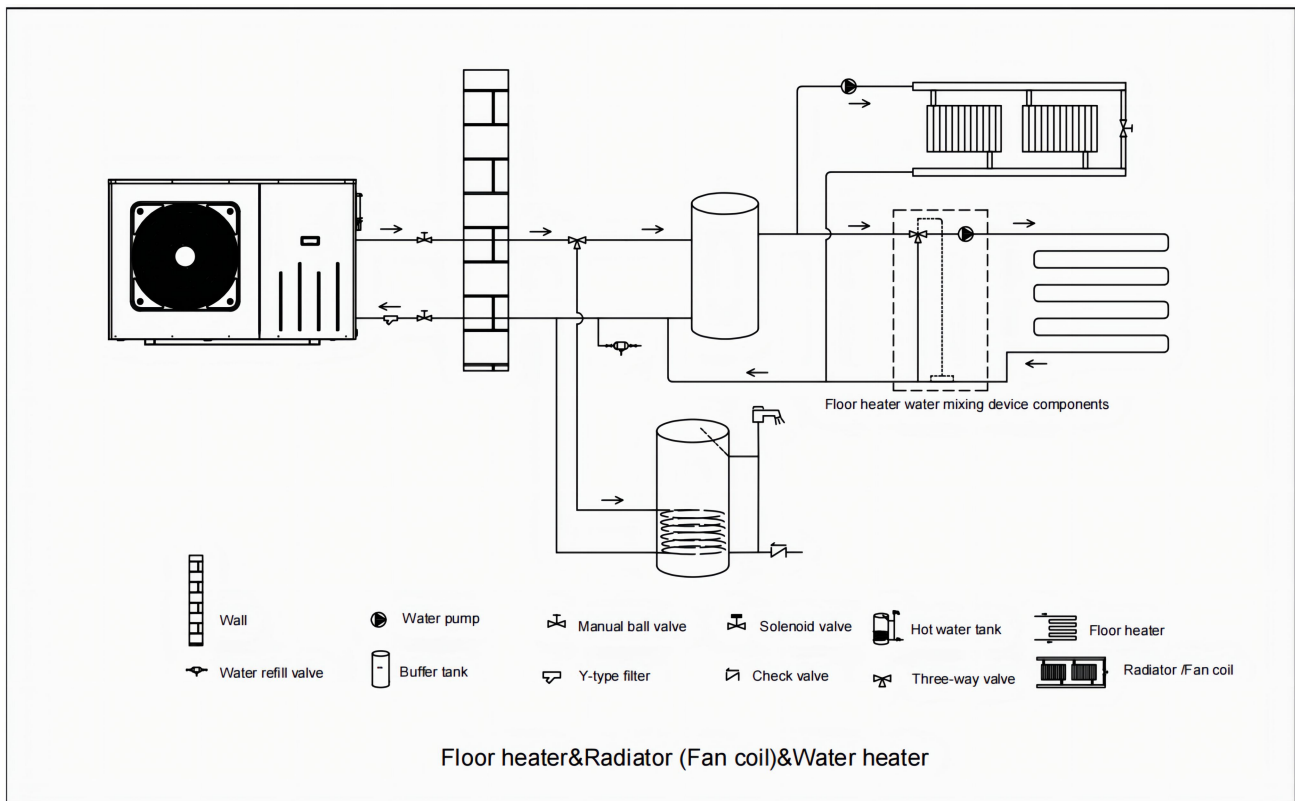

3.2.4. Electrical Installation

To function safely and maintain the integrity of your electrical system, the unit must be connected to a general electricity supply in accordance with the following regulations:

- ① Upstream, the general electricity supply must be protected by a 30mA differential switch.
- ② The heat pump must be connected to a suitable D-curve circuit breaker in accordance with current standards and regulations in the country where the system is installed.
- ③ The electricity supply cable must be adapted to match the unit's rated power and the length

of wiring required by the installation. The cable must be suitable for outdoor use.

- ④ For a three-phase system, it is essential to connect the phases in the correct sequence. If the phases are inverted, the heat pump's compressor will not work.
- ⑤ In places open to the public, it is mandatory to install an emergency stop button close to the heat pump.

Model	Power Supply Wires		
	Electricity Supply	Cable Diameter	Specification
NE-F90HCR4INVM-A	220-240V~/ 50Hz	3G 6mm ²	AWG 8
NE-F120HCR4INVM-A			
NE-F200HCR4TINVM-A	380V-415V/3N ~/ 50Hz	3G 6mm ²	AWG 8

3.2.5. Electrical Connection

⚠ WARNING: Power supply of heat pump must be disconnected before any operation. Please comply with the following instruction to connect heat pump.

Step 1: Detach electrical side panel by a screwdriver to access electrical terminal block.

Step 2: Insert cable into heat pump unit port.

Step 3: Connect power supply cable to terminal block according to the diagram below.

NE-F90HCR4INVM-A

NE-F120HCR4INVM-A

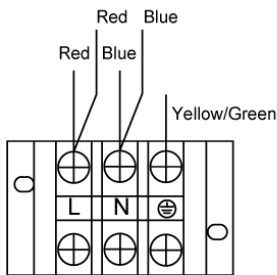

Power supply
(220-240V~/50Hz)

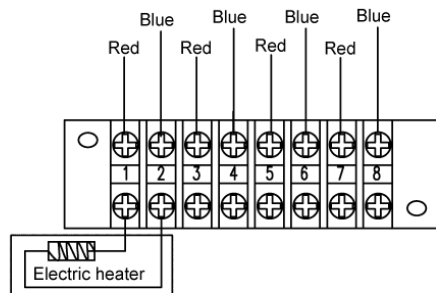

- 1, 2: Electric heater(Optional) (220-240V~/50Hz)
- 3, 4: 3-way valve (220-240V~/50Hz)
- 5, 6: Water supply pump (220-240V~/50Hz)
- 7, 8: Error alarm (220-240V~/50Hz)

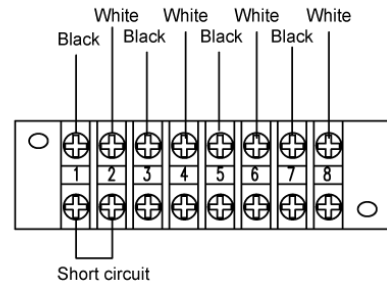

- 1, 2: Linkage switch (Passive input)
- 3, 4: Remote control mode switch 1 (Passive input)
- 5, 6: Remote control mode switch 2 (Passive input)
- 7, 8: Remote control mode switch 3 (Passive input)

NE-F200HCR4TINVM-A

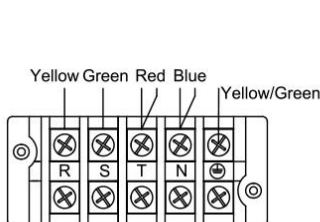

Power supply
(380-415V/3N~/50Hz)

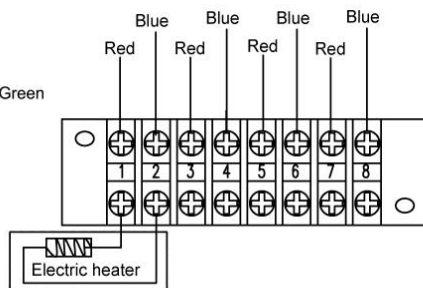

- 1, 2: Electric heater(Optional) (220-240V~/50Hz)
- 3, 4: 3-way valve (220-240V~/50Hz)
- 5, 6: Water supply pump (220-240V~/50Hz)
- 7, 8: Error alarm (220-240V~/50Hz)

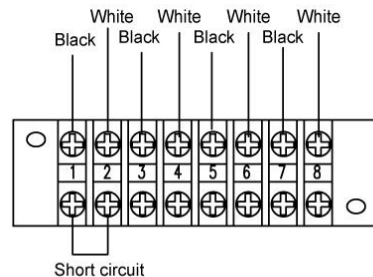

- 1, 2: Linkage switch (Passive input)
- 3, 4: Remote control mode switch 1 (Passive input)
- 5, 6: Remote control mode switch 2 (Passive input)
- 7, 8: Remote control mode switch 3 (Passive input)

3.3. Trial After Installation

 **WARNING:** Please check all the wiring carefully before turning on the heat pump.

3.3.1. Inspection Before Trial Running

Before running test, confirm below items and write √ in block;

<input type="checkbox"/>	Correct unit installation
<input type="checkbox"/>	Power supply voltage is the same as unit rated voltage
<input type="checkbox"/>	Correct piping and wiring
<input type="checkbox"/>	Air inlet & outlet port of unit is unblocked
<input type="checkbox"/>	Drainage and venting is unblocked and no water leaking
<input type="checkbox"/>	Leakage protector is working
<input type="checkbox"/>	Piping insulation is working
<input type="checkbox"/>	Ground wire is connected correctly

3.3.2. Trial Running

Step 1: Running test can begin after completing all installation;

Step 2: All wiring and piping should be connected well and carefully checked, then fill water tank with water before power is switched on;

Step 3: Emptying all air within pipes and water tank, press “on-off” button on control panel to run the unit at setting temperature;

Step 4: Items need to be checked during running test:

- ① During the first running, unit current is normal or not;
- ② Each function button on control panel is normal or not;
- ③ Display screen is normal or not;
- ④ Are there any leakage in the whole heating circulation system;
- ⑤ Condensate drain is normal or not;
- ⑥ Are there any abnormal sound or vibration during running?

4. REMOTE CONTROLLER OPERATION GUIDANCE

4.1. Main Interface

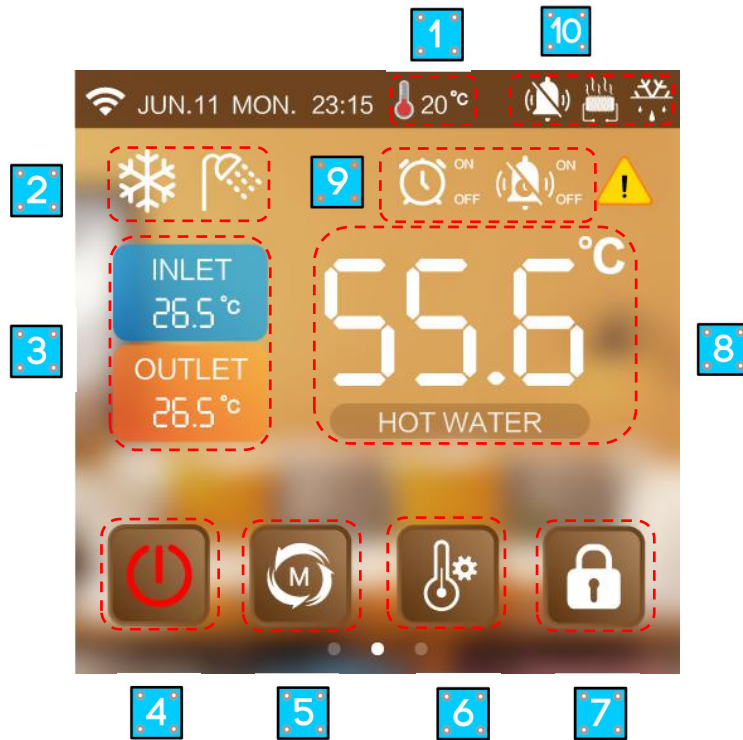

Basic Icons

- ① Ambient temp.
- ② Current mode
- ③ Inlet and outlet water temp. Cooling mode background in orange and heating mode background in blue.
- ④ ON/OFF key
- ⑤ Model key
- ⑥ Target temp. setting key
- ⑦ Lock/Unlock key
- ⑧ Water tank temp. (Without hot water mode it will not appear.)
- ⑨ Timer and timer mute ON/OFF icon
- ⑩ Mute, electric heating and defrost icon.

4.2. Key Operating Instruction

4.2.1. ON/OFF Function

At the main interface, press “” key to turn on/off. When the unit is in the off state, the interface will turn gray.

4.2.2. Mode Selection Function

At the main interface, press “” key to choose different modes. There are five modes: Heating, Cooling, Hot Water, Hot Water+Heating, Hot Water+Cooling can be selected.



4.2.3. Current Mode Target Temp. Setting

At the main interface, press “” key can enter current mode target temp. setting.

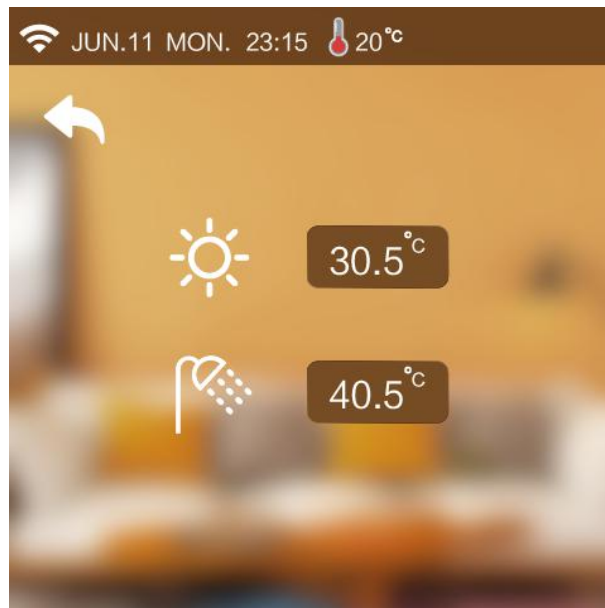

4.2.4. Check Parameter Status

At the main interface, swipe from left to right to view the current operating status. (When temp. sensor fault ,the screen display "--" .)

Status	
Unit Status	ON
Present Mode	Hot weter
Inlet Water Temp.	20.0 °
Outlet Water Temp.	20.0 °
Hot Water Temp.	20.0 °
Ambient Temp.	20.0 °
Coil Temp.	20.0 °
Exhaust Temp.	20.0 °

4.2.5. Lock/Unlock Function

At the main interface,press “” key to lock/unlock.

4.2.6. Setting Interface

At the main interface,swipe from right to left to enter the setting interface.

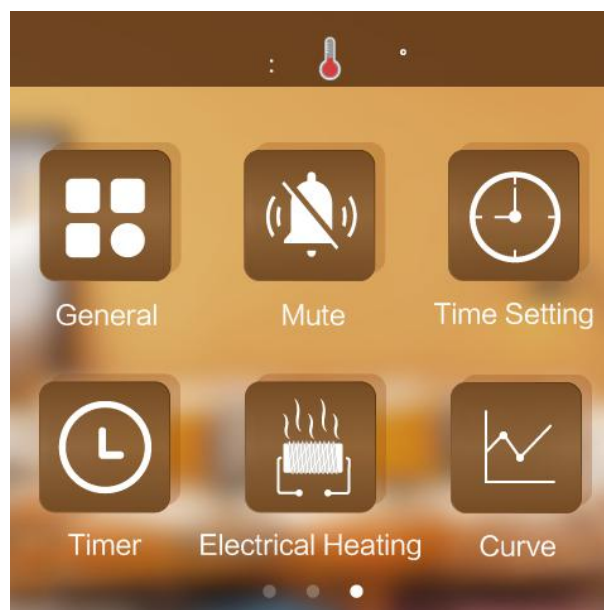

4.2.7. System Parameter Interface

At the setting interface,press “” key to enter system parameter interface

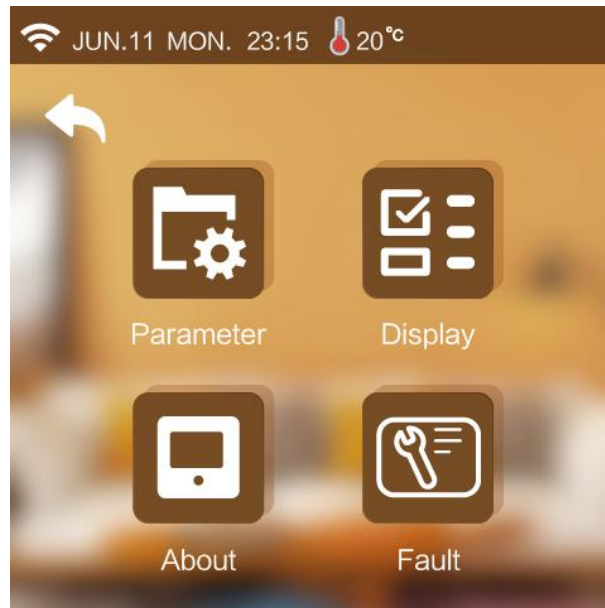

1) Customer Management Interface

At the system parameter interface, press “” key and input the password “168” to enter the customer management interface.

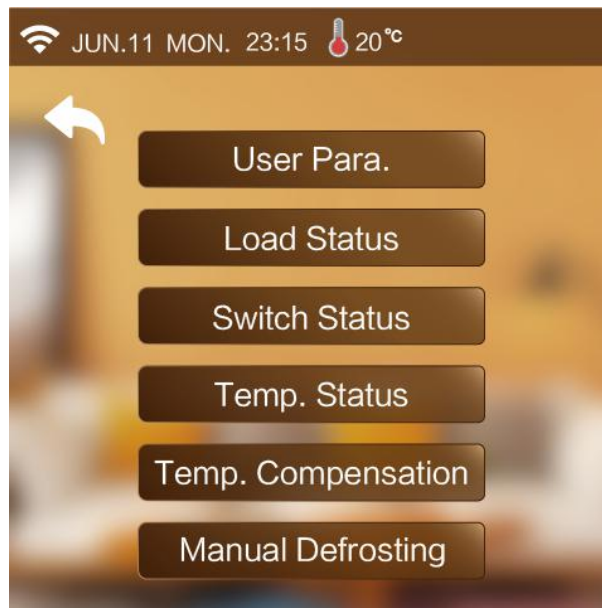

- **User parameter setting**
Press “User Para.”key can set the user parameter.
- **Temp. compensation interface**
Press “Temp. Compensation” key can enter the ambient temp. compensation interface.

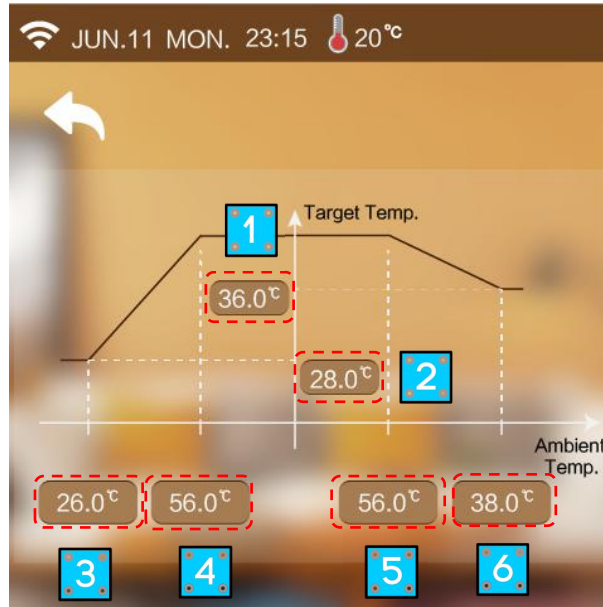

- ① Max-Compensation for high ambient temp. when heating.
- ② Max-Compensation for low ambient temp. when heating.
- ③ Compensation-off for low ambient temp.
- ④ Compensation-on for low ambient temp.
- ⑤ Compensation-off for high ambient temp.
- ⑥ Compensation-on for high ambient temp.

2) Data Backup and Recovery Interface

At the system parameter interface,press “” key and input the password “198” to enter the data backup and recovery interface.

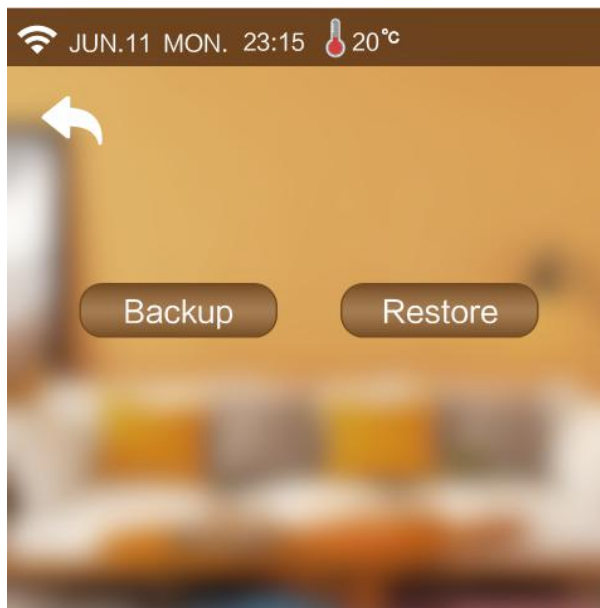

3) Restore Default Setting Interface

At the system parameter interface,press “” key and input the password “400866” to enter the

restore default setting interface.

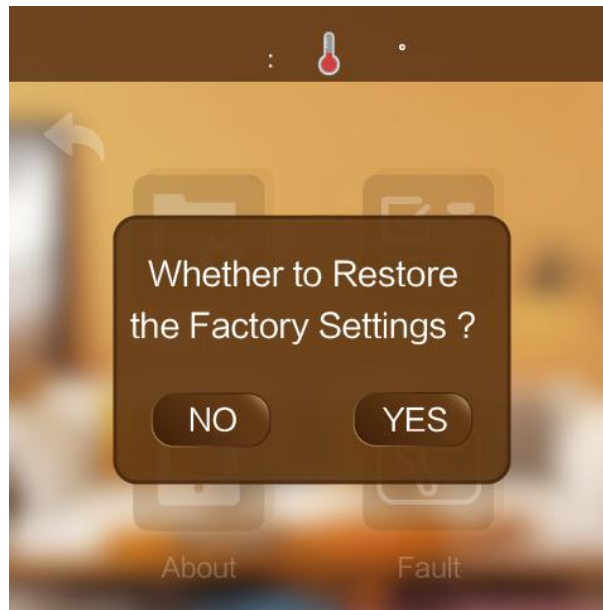

4) Factory Parameter Setting Interface

At the system parameter interface, press “” key and input the password “589” to enter the factory parameter setting interface.

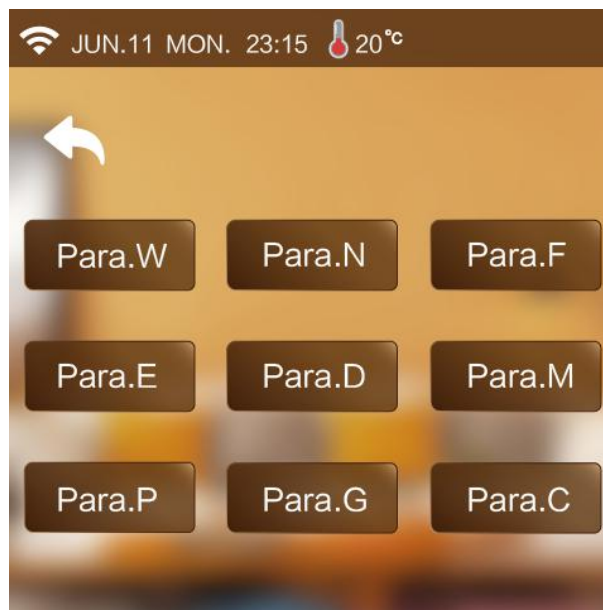

5) Display Interface

At the system parameter interface, press “” key to enter display interface.

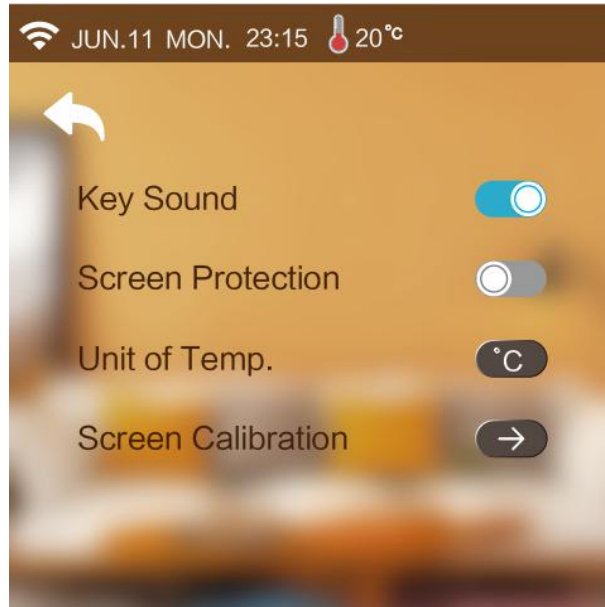

6) Machine Information Interface

At the system parameter interface,press “” key to enter display interface.

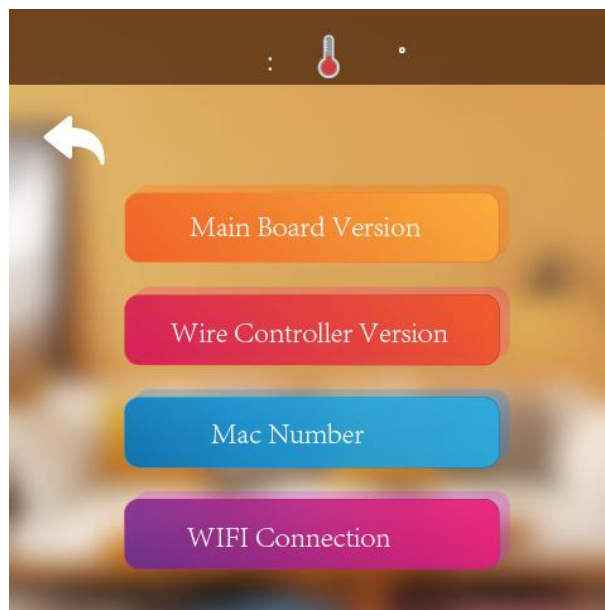

① Main Board Version

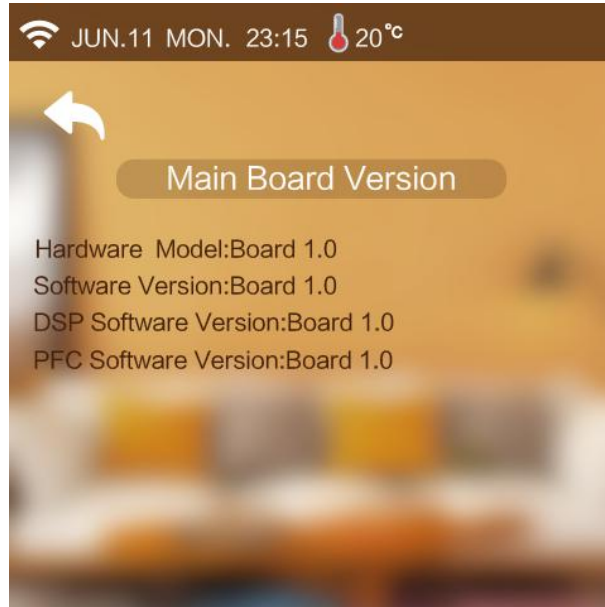

② Wire Controller Version

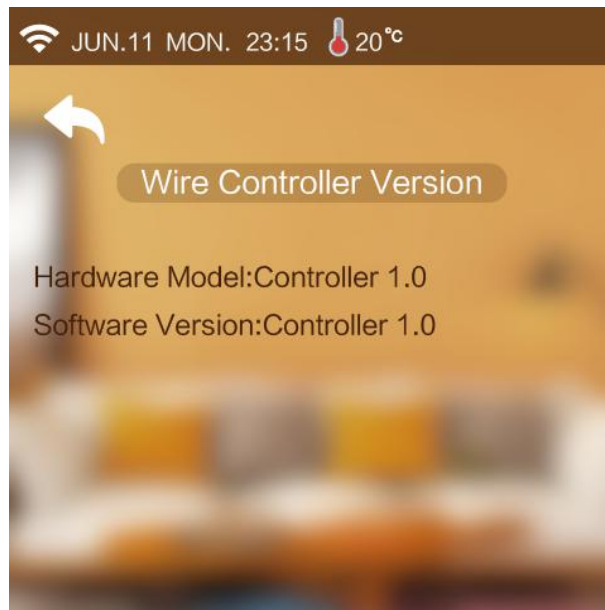

③ MAC Number

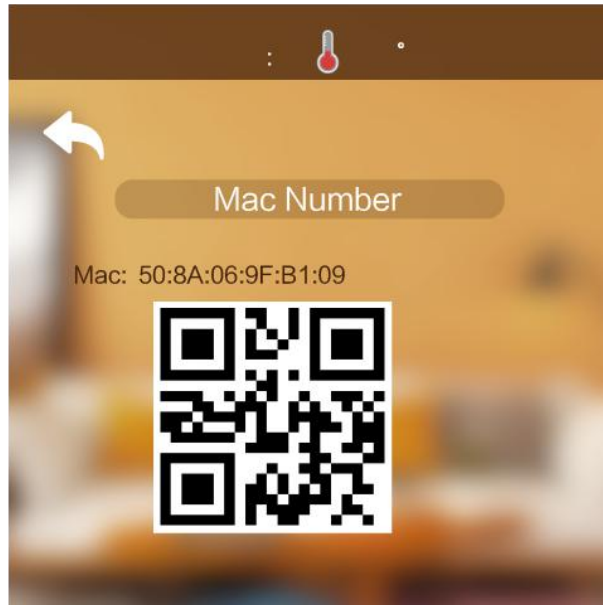

④ **Wi-Fi Connection**

Open the “Smart Lift” app to scan the QR code in the screen to connect to Wi-Fi.

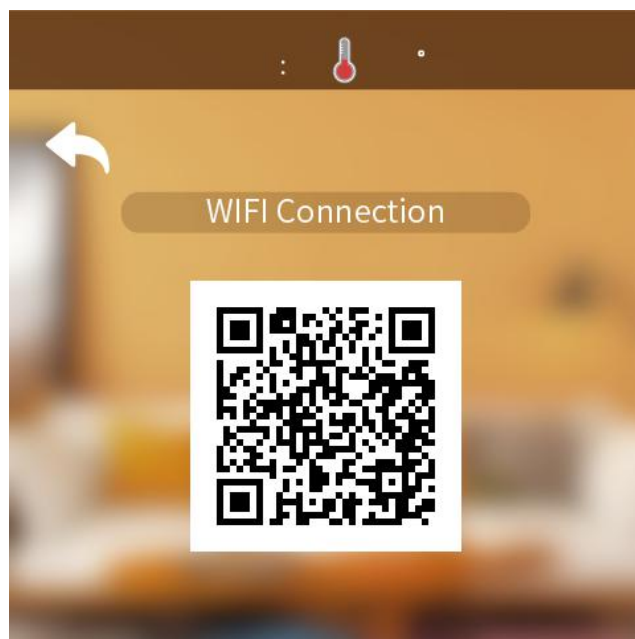

7) History Fault Interface

At the system parameter interface, press “” key to enter the history fault interface.

Type	Time
Inlet Temp. Sensor Fault	07-28 23:15:08
Flow Switch Protection 3+	07-26 21:10:06

Clear 1/8

4.2.8. Mute and Timer Mute Setting Function

At the setting interface, press  can enter mute and timer mute setting interface.

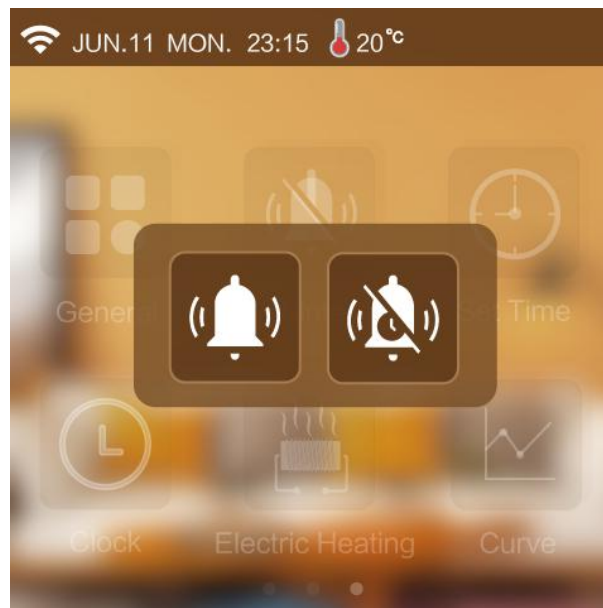

1) Mute function

: Mute status

: Non-mute status

2) Timer mute function

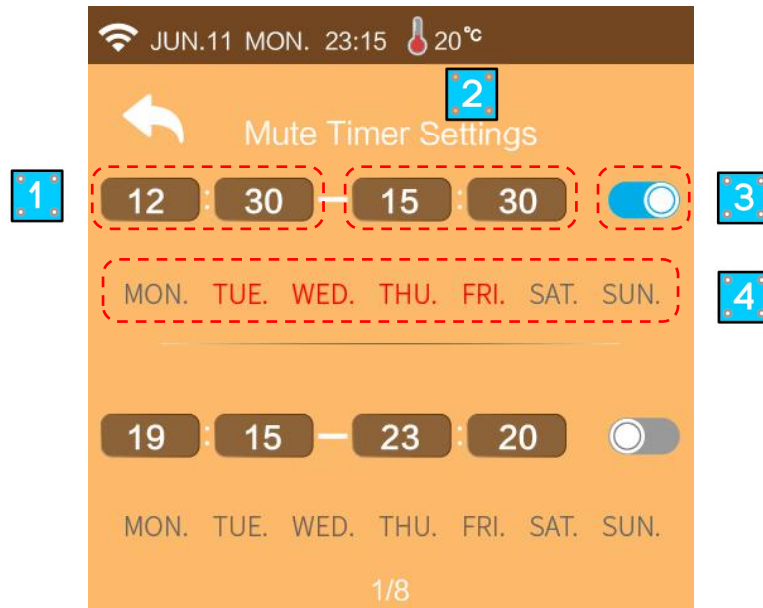

- ① Mute setting start time
- ② Mute setting end time
- ③ While the mute setting is valid, the background is blue; While the mute setting is invalid, the background is gray.
- ④ While is the mute setting valid day, the background is red;

4.2.9. Time Setting Function

At the setting interface, press “⌚” key can enter time setting interface.

- ① While the unit is °F, the time setting interface is as follow:

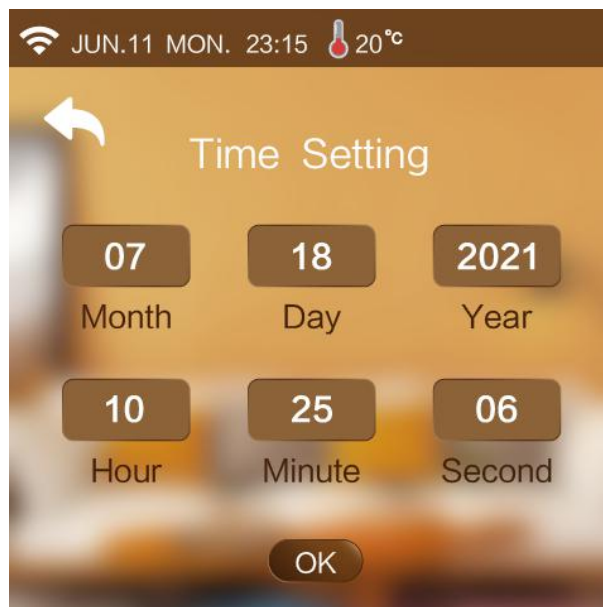



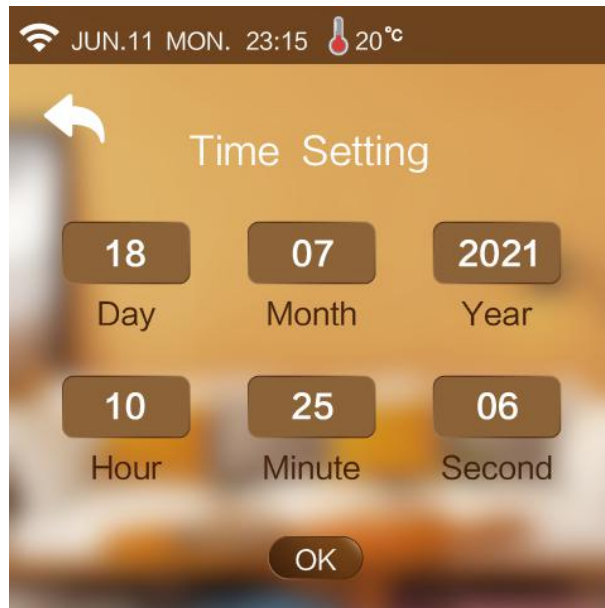

- ② While the unit is °C, the time setting page is as follow:

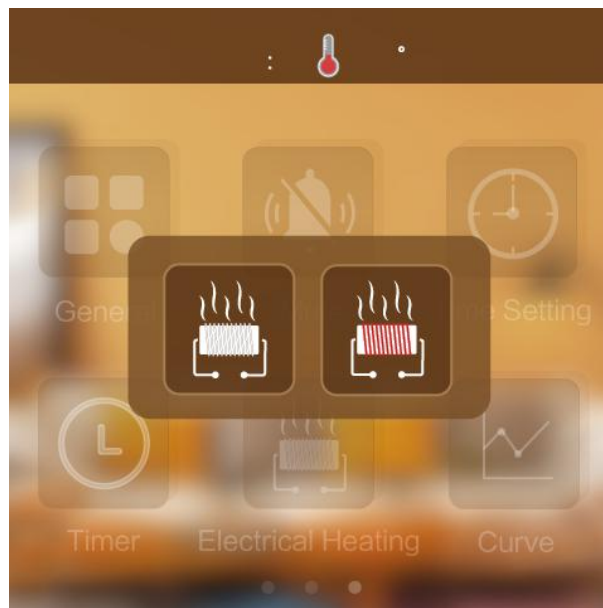

4.2.10. Electric Heating Function

At the setting interface,press “”key can enter electric heating interface.



- ①  :No electric heating function
- ②  :Turn off electric heating function
- ③  :Turn on electric heating function

4.2.11. Timer Setting Function

At the setting interface,press “”key can enter timer setting interface.

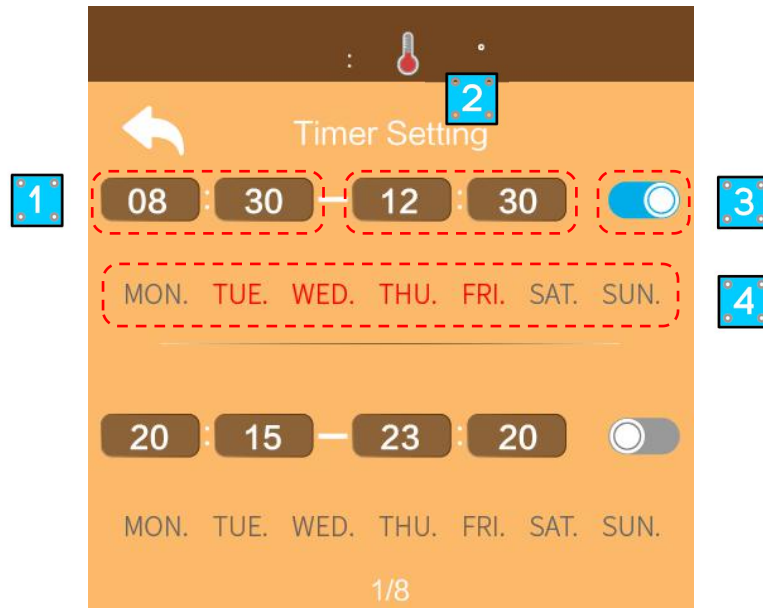

- ① Timer setting start time
- ② Timer setting end time
- ③ While the timer setting is valid, the background is blue; While the timer setting is invalid, the background is gray.
- ④ While is the timer setting valid day, the background is red;

4.2.12. Curve

- Every 3.8min to collect temp. data, every 1h to save the data. If less than 1h, the data within this period will not be saved.
- Temp. curve with power-down memory function.
- ① Celsius temp. curve

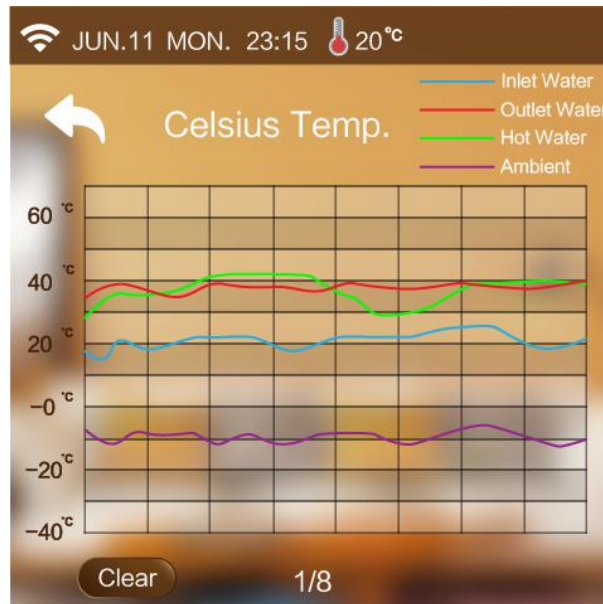

- ② Fahrenheit temp. curve

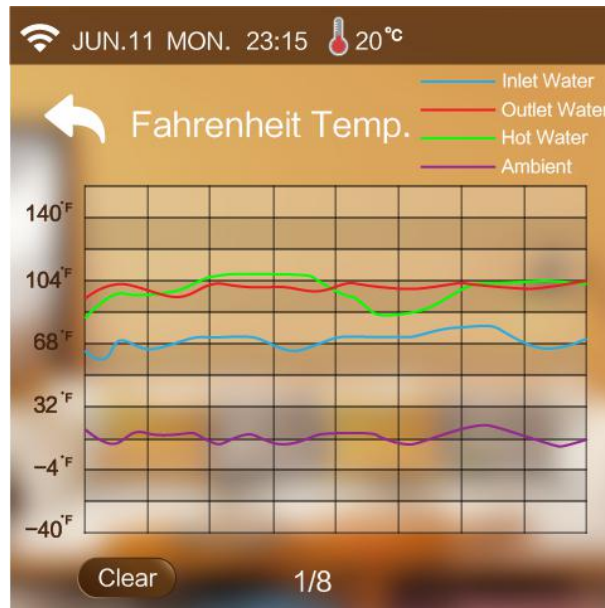

4.3. User Parameter

Code	Meaning	Range	Modbus Address	Default
G01	High Temp. Disinfection Start Time	0~23h	1287	0h
G02	High Temp. Disinfection Duration Time	0~60Min	1288	0Min
G03	High Temp. Disinfection Work Cycle	1~30days	1289	7days
G04	High Temp. Disinfection Target Temp.	60~70°C	1290	70°C
F07	Manual Mode Fan Speed	0~1300rpm	1141	0rpm
M03	Hot Water Target Temp.	R01~R02°C	1309	55°C
M06	Heating Target Temp.	R04~R05°C	1312	40°C
M09	Cooling Target Temp.	R07~R08°C	1315	12°C
M10	Power-on Return Temp. Difference	0.5~10°C	1316	2°C
M16	Compensation-on for High Ambient Temp.	-5~R17°C	1322	55°C
M17	Compensation-off for High Ambient Temp.	R16~30°C	1323	55°C
M18	Electric Heater Activation	0~2	1324	0
N03	3-Way Valve Polarity Selection	0-OFF-Heat water 1-ON-Heat water	1024	0
N06	Master/Slave Unit	0-Master/1-Slave	1027	0

4.4. Trouble Shooting

System protection/error indication

In the running process of unit, the unit may be faulted if the following code is displayed, please turn off power switch of the unit and turn on power switch of unit again after 30 seconds. The code is no longer displayed, that means the unit could be used again. If the code is displayed again, please contact our company for troubleshooting.

Code	Meaning	Note
E10	Inlet water temp. sensor fault	Alarm
E11	Outlet water temp. sensor fault	Alarm
E18	Exhaust temp. fault	Alarm
E12	Water tank temp. sensor fault	Alarm
E15	Suction temp. sensor fault	Alarm
E14	Coil temp. sensor fault	Alarm
E13	Ambient temp. sensor fault	Alarm
E16	Suction pressure sensor fault	Alarm
E17	Exhaust pressure sensor fault	Alarm
E18	Low ambient temp.protection	Alarm
E34	DC fan 1 fault	Alarm
E96	DC fan 2 fault	Alarm
E100	DC fan fault 3+	Alarm
E31	High pressure protection	Alarm
E02	Water flow protection	Alarm
E41	Low pressure protection	Alarm
E42	Level-1 anti-freezing protection in winter	Alarm
E43	Level-2 anti-freezing protection in winter	Alarm
E44	Anti-freezing protection	Alarm
E21	High exhaust temp. protection	Alarm
E35	High pressure protection 3+	Alarm
E36	Low pressure protection 3+	Alarm
E47	Anti-freezing protection 3+	Alarm
E22	High exhaust temp. protection 3+	Alarm
E50	Water flow protection 3+	Alarm
E81	IPM fault	Alarm
E93	Compressor drive fault	Alarm
E80	Compressor over-current protection	Alarm
E94	Input voltage lose phase	Alarm
E92	IPM current sampling fault	Alarm
E83	IGBT overheat shutdown protection	Alarm
E79	Compressor lose phase	Alarm
E84	PFC fault	Alarm
E89	DC bus over-voltage	Alarm
E90	DC bus under-voltage	Alarm

E88	AC input over-current	Alarm
E87	Input voltage sampling fault	Alarm
E33	DSP and PFC communication fault	Alarm
E38	Driver board temp. sensor fault	Alarm
E99	DSP and main board communication fault	Alarm
E101	DC fan board communication fault	Alarm
E39	Driver communication fault	Alarm
E05	Compressor over-current alarm	No Alarm
E06	Compressor weak magnetic protection alarm	No Alarm
E09	Power components overheating alarm	No Alarm
E19	AC input over-current alarm	No Alarm
E03	EEPROM fault alarm	No Alarm

Other Malfunctions and Solutions(No display on LED wire controller)

Phenomenon	Cause	Solution
Unit is not running	<ol style="list-style-type: none"> 1. Power outage 2. Power switch is not connected 3. Power switch fuse is burned-out 4. Timing is not up 	<ol style="list-style-type: none"> 1. Please wait for power supply recovery 2. Connect power 3. Replace fuse 4. Please wait or cancel timing setting
Unit is not running after starting up	<ol style="list-style-type: none"> 1. Compressor protection time interval is not up 2. Water temperature of the unit does not reach starting up water temperature value 	<ol style="list-style-type: none"> 1. Please wait patiently for the end of protection time 2. Normal phenomenon and wait for water temperature to reach
Unit is running normally, but hot water temperature is low	<ol style="list-style-type: none"> 1. Improper temperature setting 2. Large hot water consumption 3. Air inlet port or outlet port of outdoor machine or indoor machine is blocked 	<ol style="list-style-type: none"> 1. Set up proper temperature 2. Wait for temperature of hot water to rise 3. Clear tuyere obstruction
Unit is running automatically	Reach timing to start up	Please shutdown manually or cancel timing if needn't start up

5. Wi-Fi FUNCTION

5.1. Software Installation

- ① Method 1: Search “Smart life” in your APP store ,install “”.Click “GET” to install.

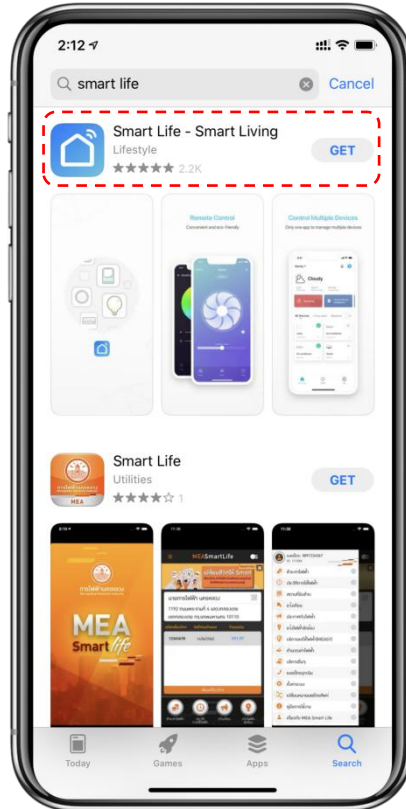

- ② Method 2: Scan the QR code below.



5.2. Software Startup

After installation,click “” on your desktop to start up Smart Life.



5.3. Software Registration and Configuration

1. Registration

① Users don't have account can click "Register" to create an account: Register → Enter your phone number → Get Verification Code → Enter Verification Code → Set Code;

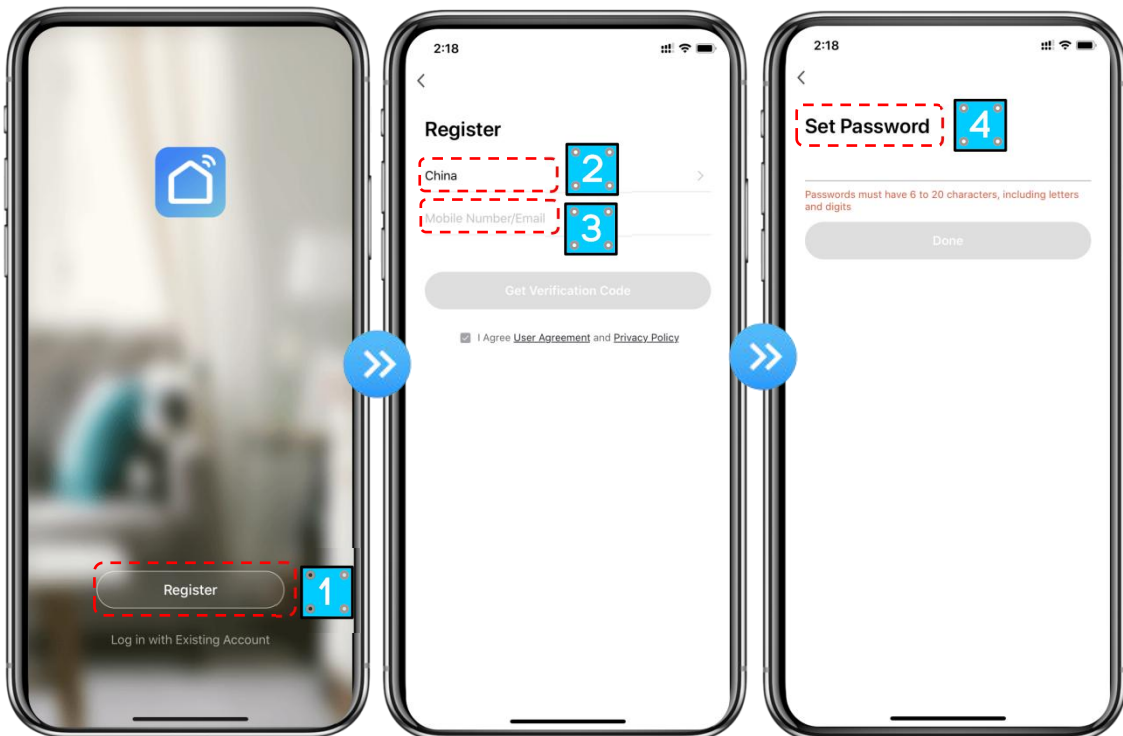

② After registration, you need to Create a Home: Create a Home → Set Home Name → Set Home Location → Add Rooms.

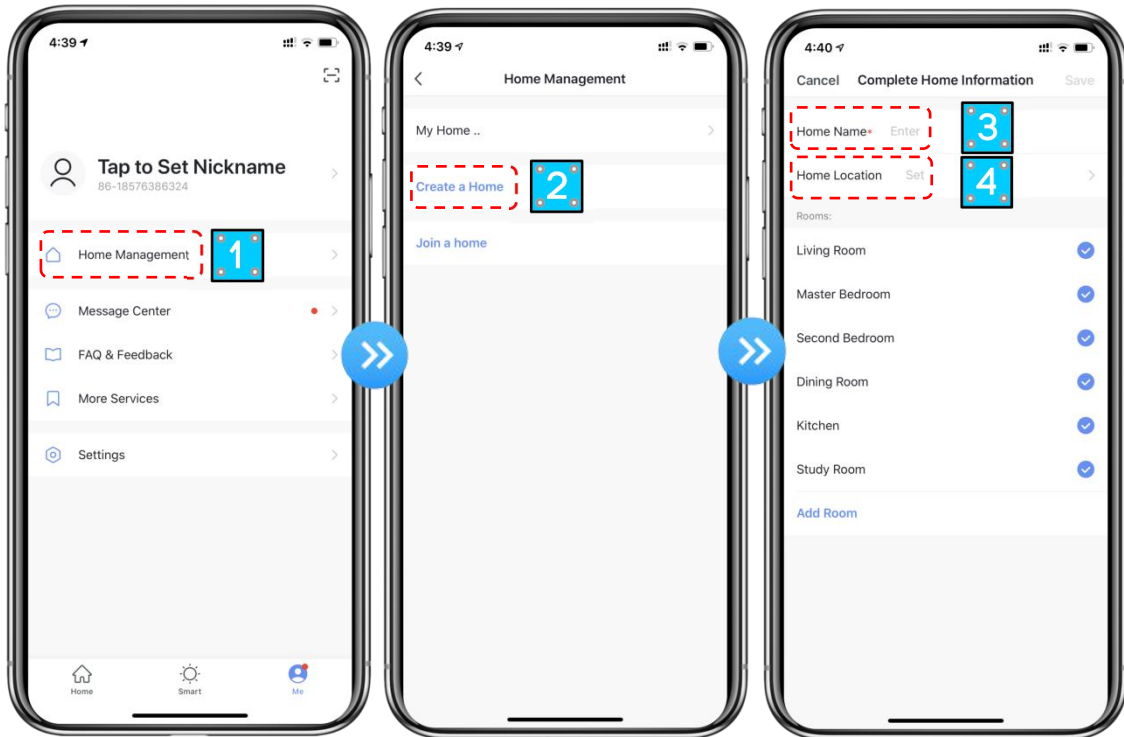

2. Account ID+ Password Login

- ① Existing accounts can be logged in directly, in the following order.

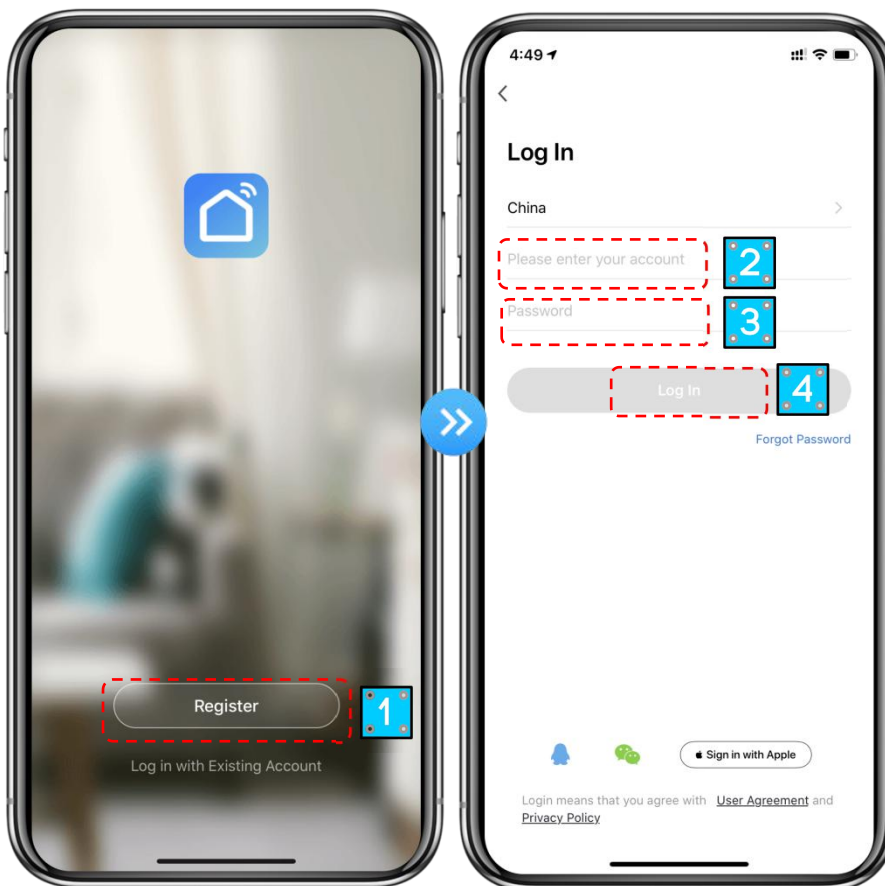

② If you forget your password you can choose to login with your verification code and select "Forget Password": Enter your phone number → Get verification code .

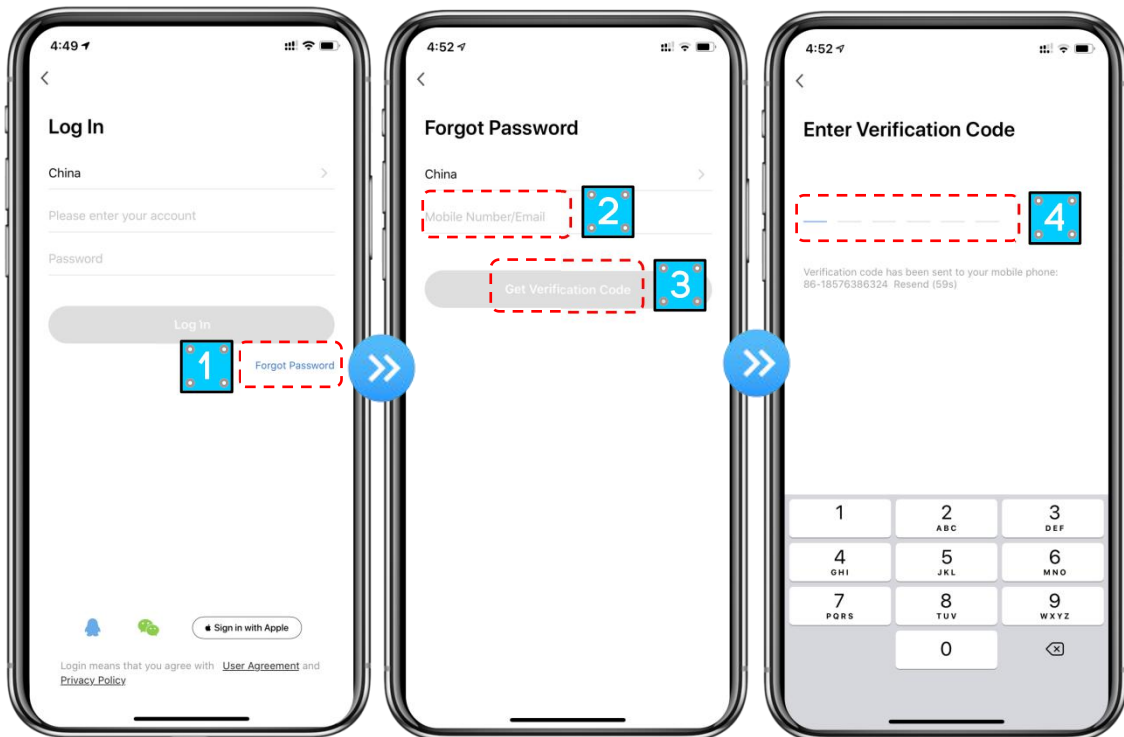

③ After creating a home or logged in, enter the main interface of APP.

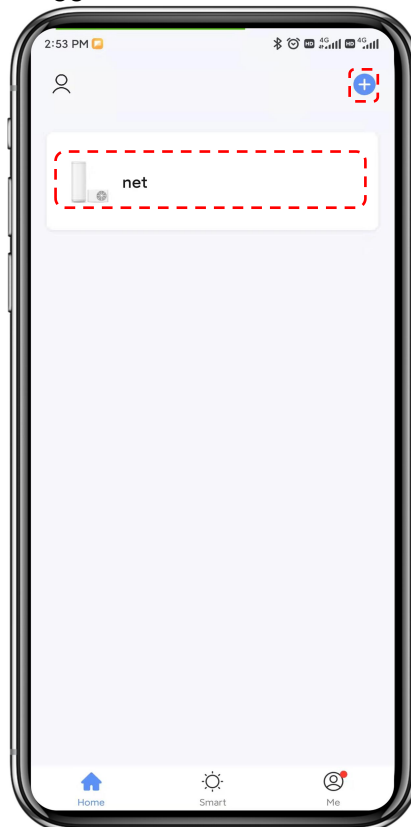

Note:

Click the device to check the status, and you can set the operating mode, ON/OFF, timer.
Click “+” to add devices.

5.4. WI-FI Connection

Method 1(Scan the QR code to connect)

Step 1:

The air source heat pump water heater enter the EZ mode:General ➡ about ➡ Wi-Fi Connection , then there will a QR code appears on the screen of the wire controller, the interface is as follows:

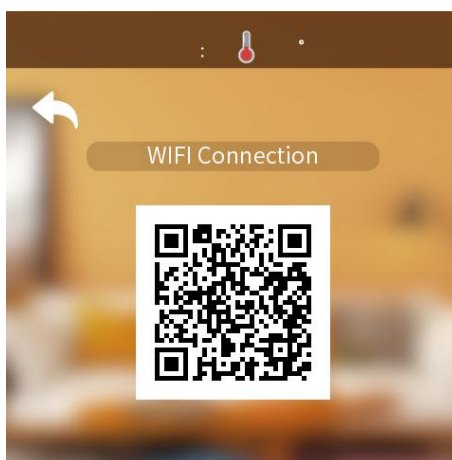

Step 2:

Turn on the phone's Bluetooth and Wi-Fi function , then connect to the Wi-Fi hot-spot. The Wi-Fi hot-spot must be able to connect to the Internet normally;

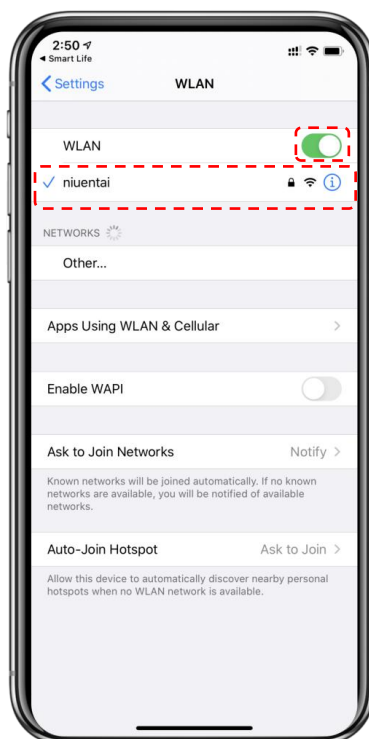

Step 3:

Open the "Smart life" APP, log in into the main interface, click on the top right corner "+" of the interface, enter the equipment type selection interface, click on the top right corner "🔍" of the interface, scanning the QR code on the screen for device connection.

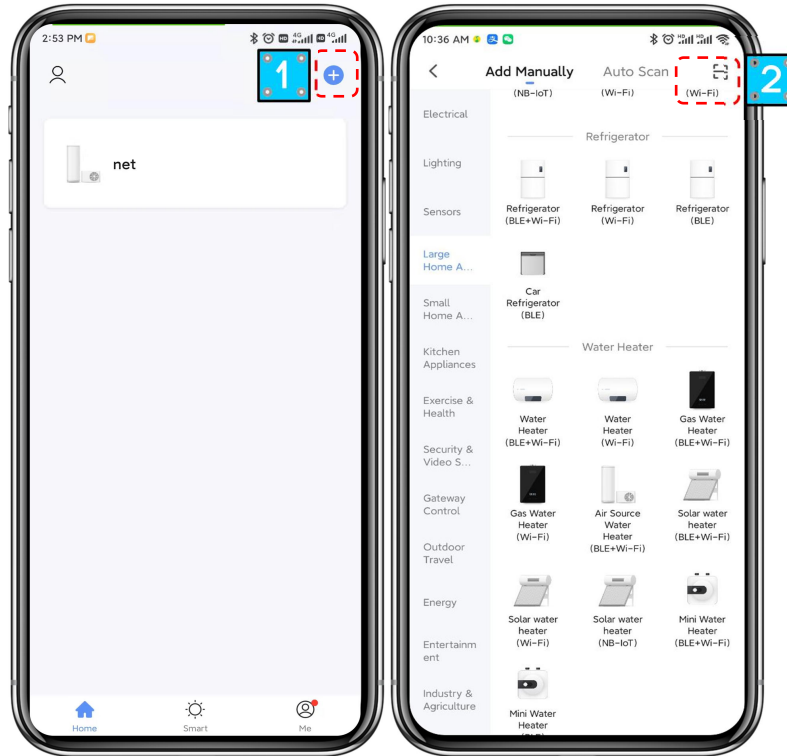

Step 4: Click "Add", and then directly enter the connected status of the device, the user interface is as follows:

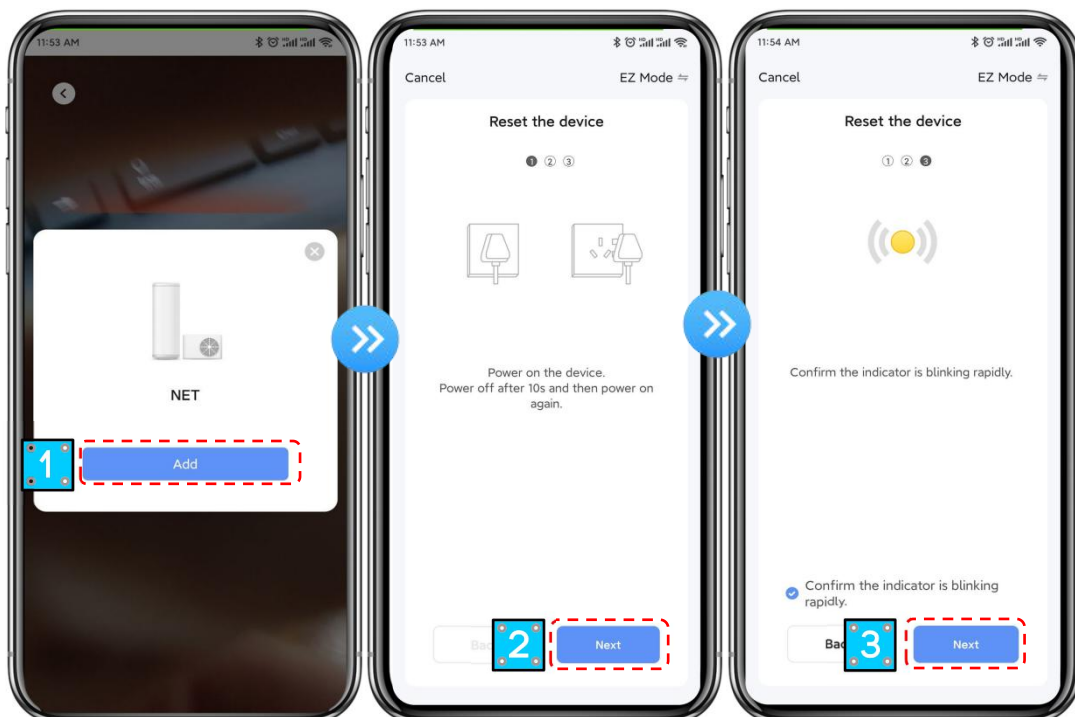

Step 5:

When “Scan devices”, “Register on Cloud”, “Initialize the device” are all completed, connect succeeds.

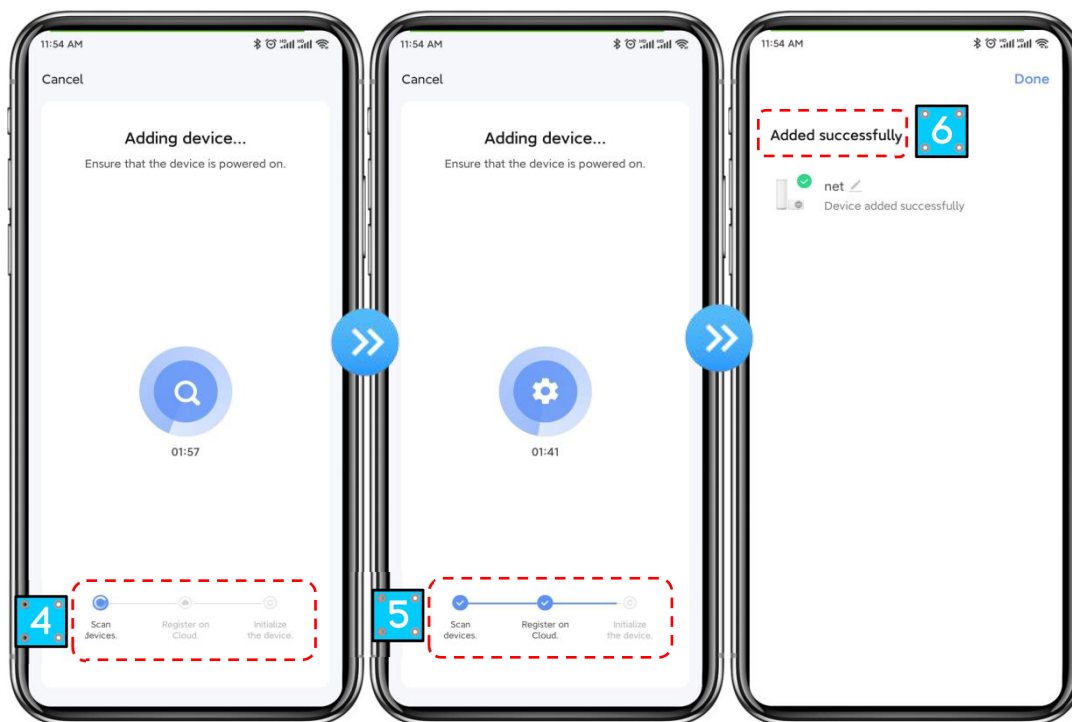

Method 2 (Add Manually)

Step 1

Turn on the phone's Bluetooth and Wi-Fi function, then connect to the Wi-Fi hot-spot. The Wi-Fi hot-spot must be able to connect to the Internet normally.

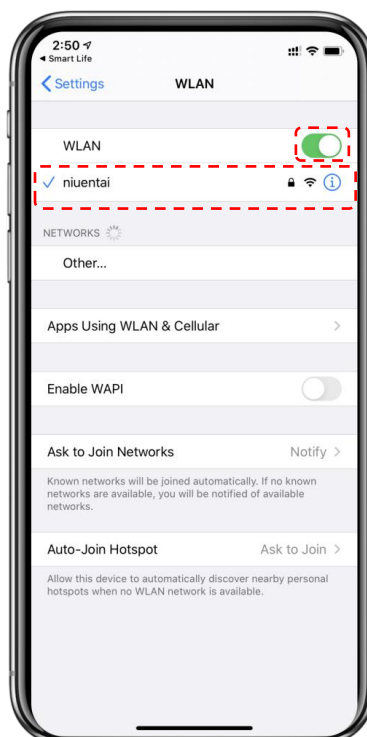

Step 2

Open the "Smart life" APP, log in into the main interface, click on the top right corner "+" or "add equipment" of the interface, enter the equipment type selection, the "Large Home Appliances", select "Air Source Water Heater(BLE+Wi-Fi)" equipment and add equipment into the interface.

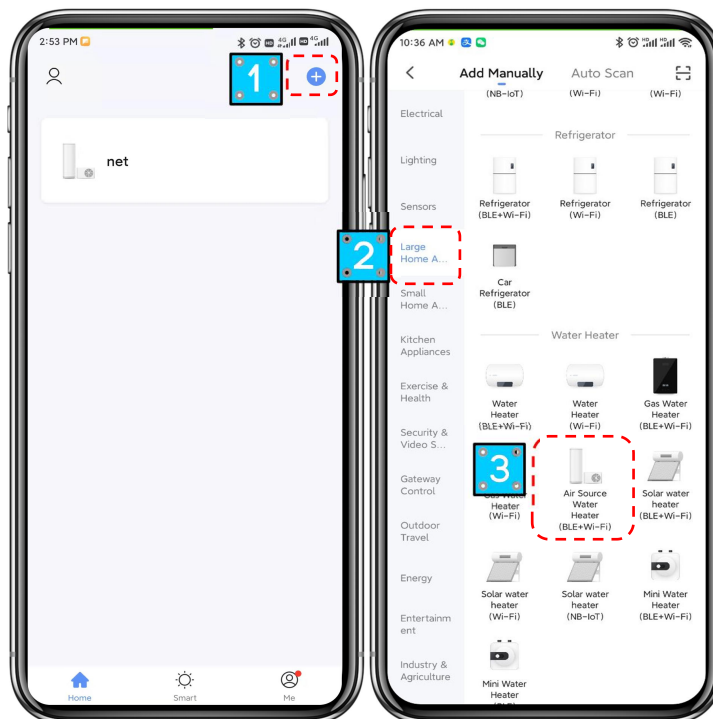

Step 3

After entering the add device interface, click "Confirm the indicator is blinking rapidly" and "Next"; The interface of Wi-Fi connection will pop up, enter the Wi-Fi password of the mobile phone (it must be the same as the Wi-Fi of the mobile phone), click "Next". Enter the mobile phone Wi-Fi connection interface, and the APP will automatically enter the device connection status.

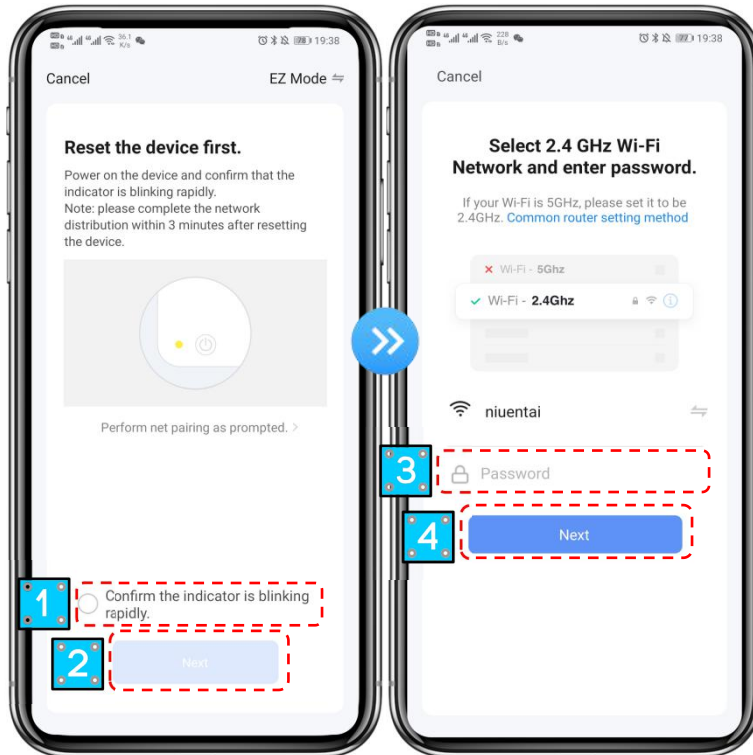

Step 4&5

Same as Method 1 above.

5.5. Software Function Operation

- After the device is bound successfully, enter the operation interface of “Smart heat pump” (Device name, modifiable)
- In the main interface of “Smart Life”, click “Air Source Water Heater(BLE+Wi-Fi)” to enter the operation interface.

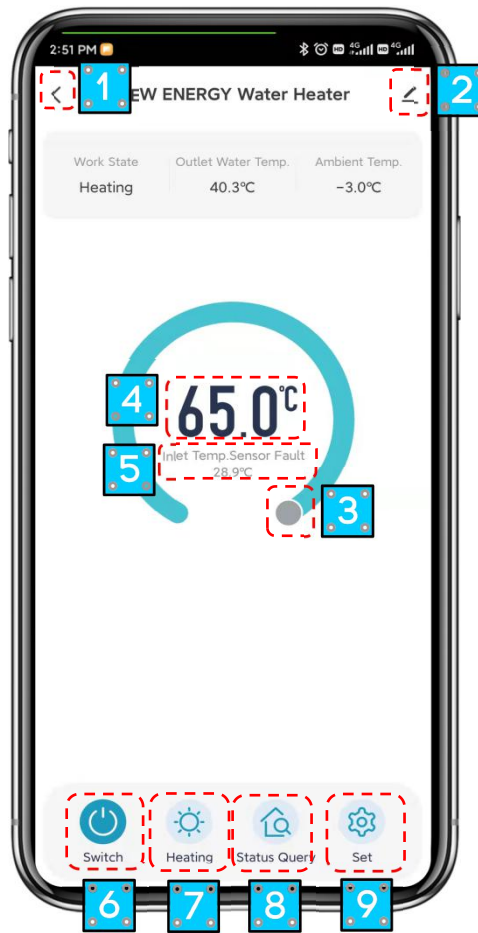

- ① Back
 - ② More: You can change device name, select device installation location, check networking status, add Shared users, create device cluster, view device information, and more.
 - ③ Setting temperature adjustment: The grey circle slides counterclockwise to reduce the temperature, ,but clockwise to increase the temperature.
 - ④ Target temperature
 - ⑤ Inlet temperature
 - ⑥ ON/OFF
 - ⑦ Mode switching: Click to select the mode to be switched.
 - ⑧ Status Query
 - ⑨ Set
- **Modify device name**
- Click in the following order to enter device details, and click "Device Name" to rename the device.

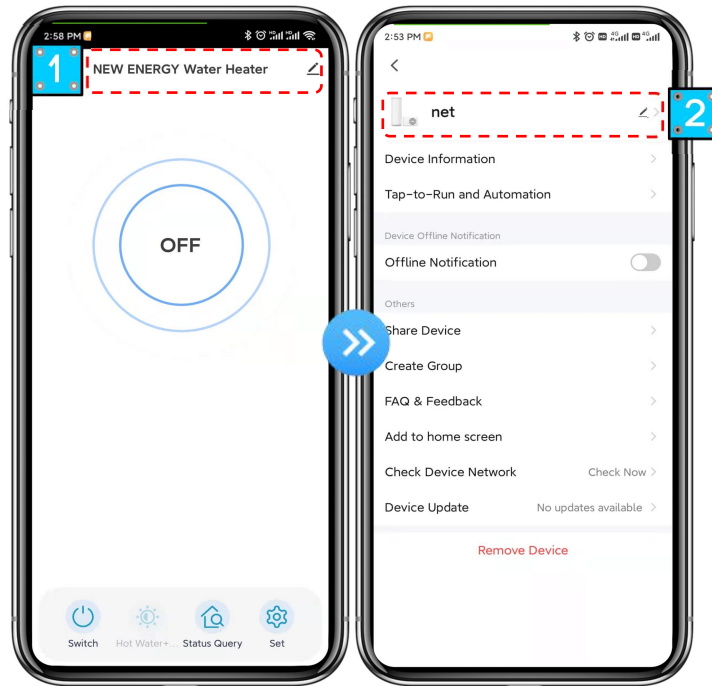

- **Device sharing**

- ◆ To share a bound device, the user should do so in the following order.
- ◆ After successful sharing, the list will be added to show the person shared
- ◆ If you want to delete the account you shared to, cross the selected account to the left, and delete it.
- ◆ The user interface is as follows.

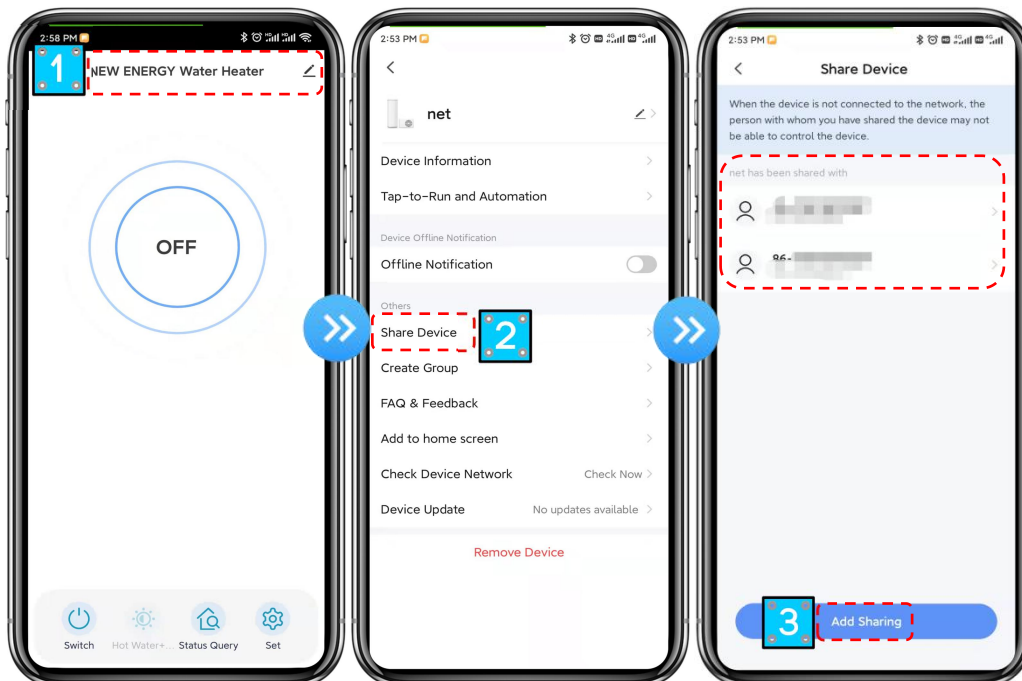

- **Mode settings**

Click "mode switching" on the main interface to switch modes, select what you need.

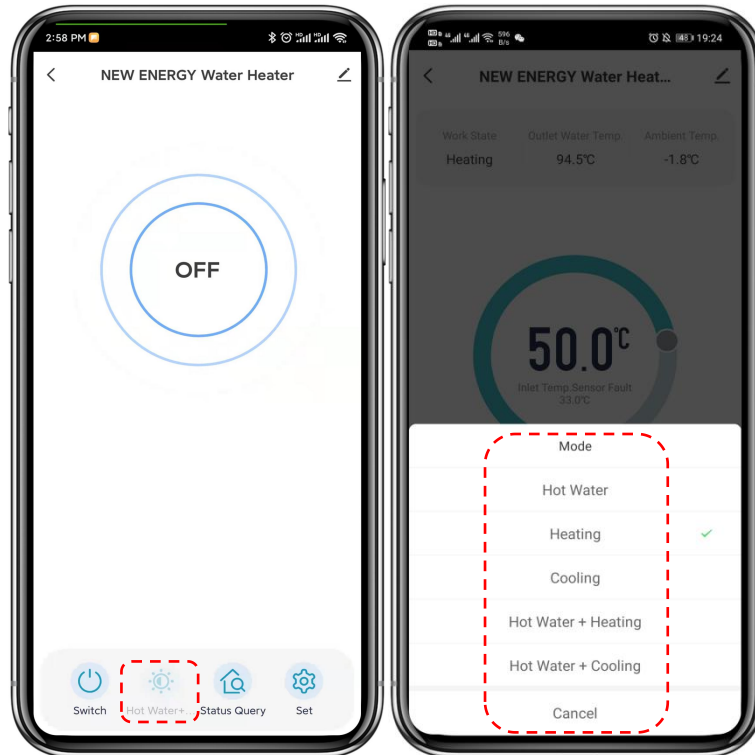

Notice:

- ① APP is not allowed to turn on the electric heating and defrost functions when the unit is running in cooling mode.
- ② When the hot water mode is not enabled: APP don't display the hot water temperature.
- ③ When the unit is switched off: the mode can't be modified and displayed wave dynamic.
- ④ Sliding adjustment in the middle of the power on can currently only adjust the hot water target temperature (Adjust other parameters need to be customized).

● **Status Query**

(1) Temperature curve.

The current curve shows the temperature respectively: water outlet temperature, water inlet temperature, hot water temperature, ambient temperature, and the temperature curve is recorded every 15 minutes.

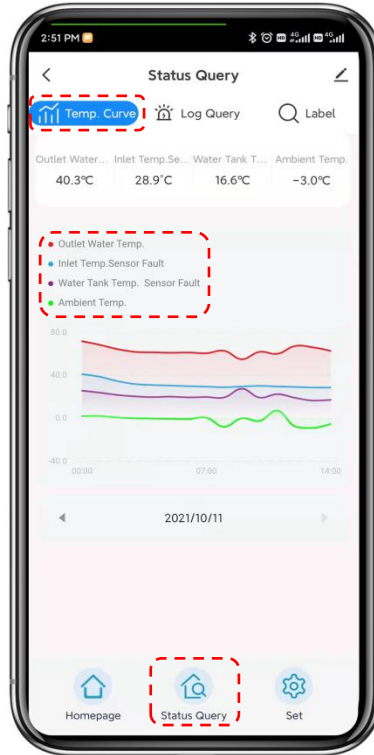

(2) Log Query and Label

Log records can be saved for 7 days, the operation log will record the operation content are: switch on/off, mode, defrost, electric heating, timer mute.

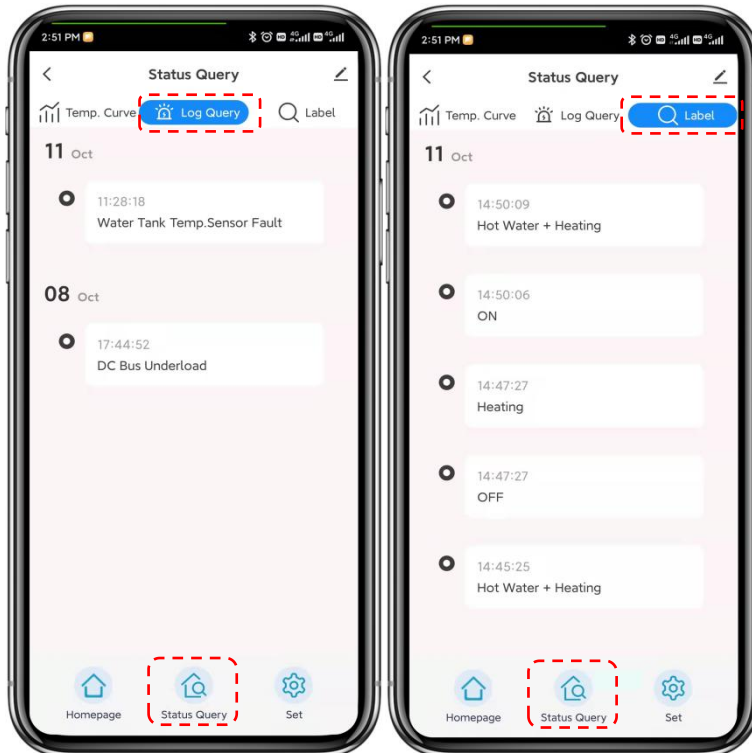

● Parameter Setting

1.Target temperature setting

- (1) Support to modify the content of the parameters are: hot water target temperature, cooling target temperature, heating target temperature, temperature units (in the modification of temperature units, the controller will re-read the main board and upload to the APP one by one).

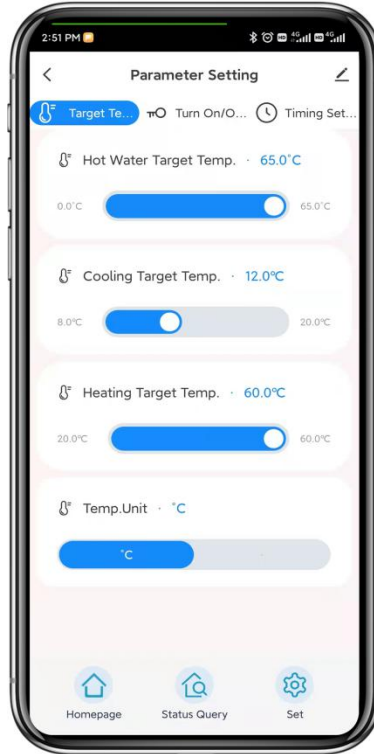

(2) Switch settings

- ① Defrosting: not allowed to be switched on in the operating refrigeration state.
- ② Electric Heating: not allowed to be turned on in the running cooling state.
- ③ Time Mute: issued to the main board is actually a timed mute flag bit.

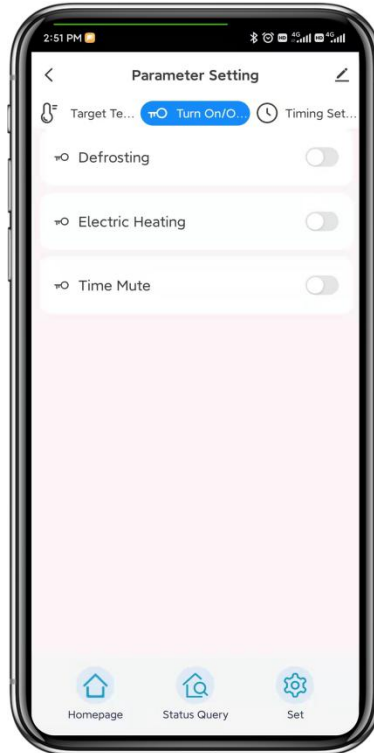



(3) Timing settings (timing function supports a total of 30 groups of timing functions)

① Timer Turn ON/OFF: switch on/off

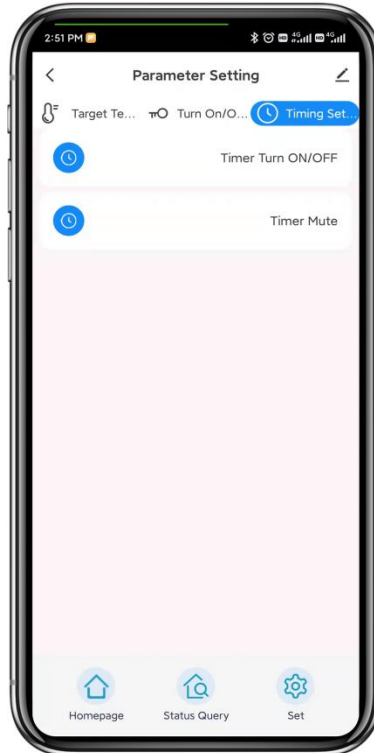
② Timer Mute: On/Off Timer

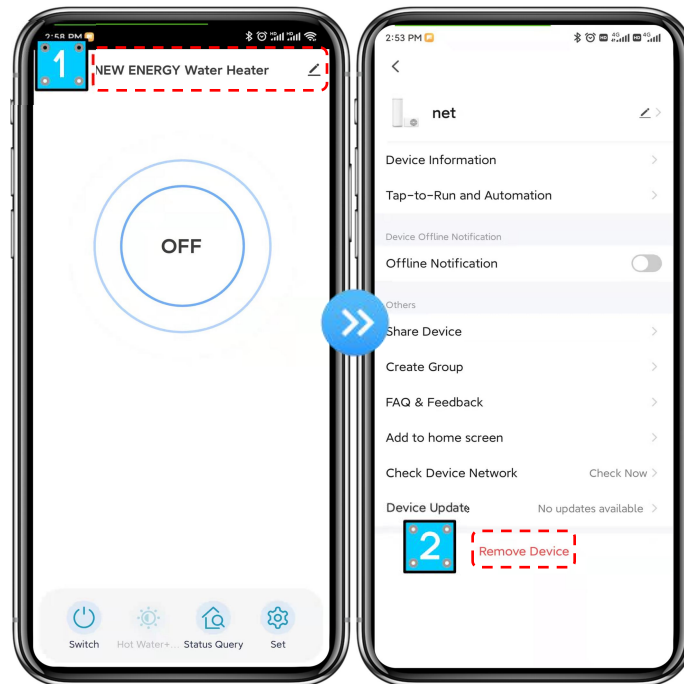

5.6. Device Removal

Click “

The image displays two smartphone screens side-by-side, illustrating the steps for device removal. The left screen shows the main interface for a device named "NEW ENERGY Water Heater". The device status is "OFF", indicated by a large "OFF" text in the center. A red dashed box highlights the edit icon (a pencil) in the top right corner. The bottom navigation bar includes icons for "Switch", "Hot Water+", "Status Query", and "Set". The right screen shows the "net" device details page. A red dashed box highlights the "Remove Device" button at the bottom. A blue arrow points from the edit icon on the left screen to the "Remove Device" button on the right screen.

6. MAINTENANCE AND WINTERIZING

6.1. Maintenance

 **WARNING:** Before undertaking maintenance work on the unit, ensure that you have disconnected the electrical power supply.

- **Cleaning**

- The heat pump's casing must be cleaned with a damp cloth. The use of detergents or other household products could damage the surface of the casing and affect its properties.
- The evaporator at the rear of the heat pump must be carefully cleaned with a vacuum cleaner and soft brush attachment.

- **Annual maintenance**

The following operations must be undertaken by a qualified person at least once a year.

- Carry out safety checks.
- Check the integrity of the electrical wiring.
- Check the earthing connections.
- Monitor the state of the pressure gauge and the presence of refrigerant.

6.2. Winterizing



**“CUT OFF” power supply of the heater
before cleaning, examination and repairing**

When you don't use:

- Cut off power supply to prevent any machine damage.
- Drain water clear of the machine.

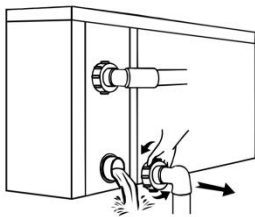

!! Important:

Unscrew the water nozzle of inlet pipe to let the water flow out.

- Cover the machine body when not in use.

106-10004-393